



national treasury

Department:
National Treasury
REPUBLIC OF SOUTH AFRICA

**STANDARD CHART OF
ACCOUNT SPECIFIC TO
LOCAL GOVERNMENT**

*SCOA for MUNICIPALITIES-
mSCOA*

Project Detail:

**– Item Segment – Assets,
Liabilities and Net Assets**

January 2023 (Version 6.7)

ASSETS, LIABILITIES AND NET ASSETS.....	4
Background to the Segment.....	4
Relevance of the Item Segment Assets, Liabilities and Net Assets, Methodologies and Application thereof in the context of <i>mSCOA</i>	4
Illustration: High-level Classification	4
Design Principles.....	6
Legislative and Regulatory Requirements	13
For the legislative and regulatory requirements refer to Annexure A of the PSD ...	13
Transactions by Business Process to be allocated in this Segment.....	13
Category Links and Business Rules	14
Discussion of the Segment.....	16
Assets.....	16
Current Assets	16
Cash and Cash Equivalents	17
Cash at Bank.....	18
Call Deposits and Investments.....	20
Construction Contracts and Receivables	21
Current Portion of Non-Current Receivables/ Non-current Receivables	26
Receivables from Non-Exchange Transactions	31
Property Rates.....	32
Operating Lease – Straight Line.....	35
Control, Clearing and Interface Accounts.....	35
Income Tax Receivable/ Payable.....	36
Inventory.....	36
Trade and Other Receivables from Exchange Transactions	43
Affiliated/Related Parties/ Associated Companies.....	44
Prepayments and Advances (including Impairment).....	44
Trading Service and Customer Service Debtors.....	47
VAT Receivable and Payable.....	51
Deposits.....	53
Non-current Assets	53
Biological Assets	53
Defined Benefit Assets (Non-current Assets)/ Defined Benefit Obligations (Non-current Liability).....	56
Defined Benefit Assets (Non-current Assets).....	56
Defined Benefit Asset (Current Assets)	57
Deferred Tax	57
Heritage Assets	57
Investments in Associate	65
Investments in Joint Venture	66
Investment Property	66
Investment in Subsidiary	71
Investment	71
Property, Plant and Equipment.....	73
Revaluation Model.....	76
NERSA Requirements	78
Classes of Property, Plant and Equipment	80
Depreciation and Accumulated Depreciation	84
Assets Acquired and No Cost or Nominal Cost	89
Infrastructure Assets	89

Leased Property, Plant and Equipment.....	90
Initial recognition	90
Depreciation and Accumulated Depreciation	90
Impairment	91
Classes of Property, Plant and Equipment	91
Construction Work-in-progress	92
Liabilities.....	96
Current Liabilities	97
Bank Overdraft	100
Consumer Deposits	100
Financial Liabilities	101
Unamortised Premium on Long-term Debts	101
Concessionary Loan	101
Short-term Borrowing	101
Current portion of Non-Current Borrowings	103
Current/ Non-current portion of Finance Lease Liabilities.....	105
Income Tax Payable	106
Current and Non-Current Provision and Impairment.....	106
Provision	106
Impairment.....	107
Decommissioning Restoration and Similar Liabilities	110
Onerous Contracts	111
Trade and Other Payable Exchange Transactions.....	112
Trade and Other Payable Non-Exchange Transactions	116
VAT Payable (Control)	119
VAT Credit: Output Accrual.....	119
Output VAT.....	120
Output VAT: Provision for Doubtful Debt Impairment	120
Intercompany/ Parent Subsidiary Transactions	120
Defined Benefit Obligations.....	120
Deferred Tax Liabilities.....	120
Non-current Liabilities	121
Deferred Tax Liabilities.....	121
Defined Benefit Obligations.....	121
Financial Liabilities	122
Borrowings	122
Finance Lease Liability	122
Operating Lease Liability	122
Provision and Impairment.....	122
Net Assets.....	123
Accumulated Surplus/(Deficit)	123
Equity.....	124
Non-controlling Interest.....	125
Reserves and Funds	125
Preparation for mSCOA Implementation	129
Annual Maintenance and Matters Pending.....	129
Annual Maintenance	129
Matters Pending	129

ASSETS, LIABILITIES AND NET ASSETS

Background to the Segment

Relevance of the Item Segment Assets, Liabilities and Net Assets, Methodologies and Application thereof in the context of *mSCOA*

The financial position of the municipality is affected by the resources it controls, its financial structure, its liquidity and sustainability, and its capacity to adapt to changes in the environment in which it operates. The Item Segment with its component for assets, liabilities and net assets hosts the classification structure for providing this information.

The sequence of accounts depicted in the code structure defined in the *mSCOA* Chart does not indicate the order or format in which items are to be presented in the annual financial statements, resulting in a contradiction to the presentation requirements provided for in the Standards of GRAP 1¹ Presentation of Financial Statements.

In addition, **the requirement to apply judgement** on whether additional items are separately presented based on an assessment of the nature and liquidity of assets, the function of assets within the municipality; and the amounts, nature and timing of liabilities **does not change at the implementation of *mSCOA***. *mSCOA* requires the information as guided by the classification framework as a minimum and does not focus as such on determining materiality. Standard classification is critical to collecting comparable, uniform and quality information for statistical and oversight reporting. Management must (as in the past) continue to apply judgement in financial statement compilation within the materiality framework relevant to the municipality in presenting information.

National Treasury compiled Specimen Financial Statements since 2019 that provide guidance on linking the *mSCOA* accounts to the financial statement presentations.

Illustration: High-level Classification

The illustration of the high-level classification structure for this segment directly relates to the main classifications required in the Statement of Financial Position in accordance with the requirements of the *Standards of GRAP 1 Presentation of Financial Statements*.

The determination on classifying assets and liabilities as current or non-current need to be guided by the requirements set-out in the above Standard of GRAP read with any other requirements set-out in a Standard of GRAP. The definitions provide brief explanations in the context of *mSCOA* , but might not be sufficient in determining the current versus non-current classifications.

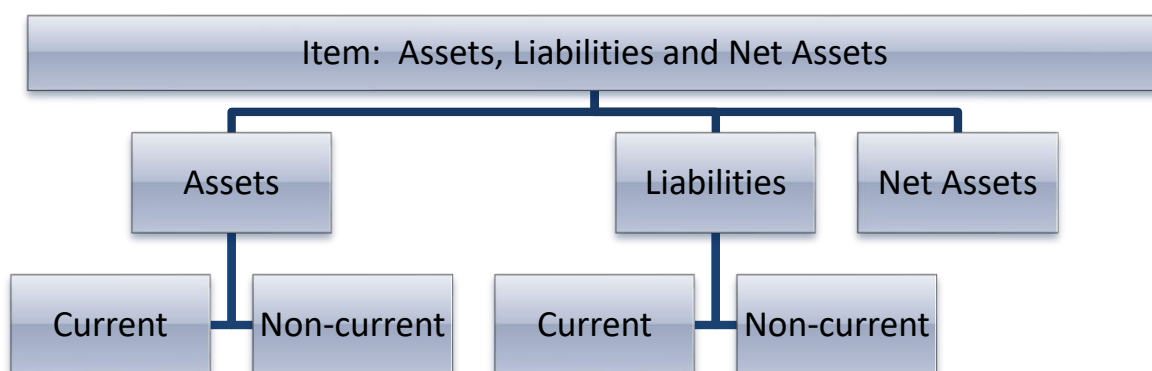

Definition:

Assets: Assets are resources controlled by the entity as a result of past events and from which future economic benefits or service potential are expected to flow to the entity.

Current Assets: An asset shall be classified as current when it satisfies any of the following criteria:

- (a) it is expected to be realised in, or is held for sale or consumption in, the entity's normal operating cycle;
- (b) it is held primarily for the purpose of being traded;
- (c) it is expected to be realised within twelve months after the reporting date; or
- (d) it is cash or a cash equivalent asset (as defined in the Standard of GRAP 2 on Cash Flow Statements) unless it is restricted from being exchanged or used to settle a liability for at least twelve months after the reporting date.

Non-current Assets: All other assets not classified as current according to the definition above shall be classified as non-current.

Liabilities: Present obligations of the entity arising from past events, the settlement of which is expected to result in an outflow from the entity of resources embodying economic benefits or service potential.

Current Liabilities: A liability shall be classified as current when it satisfies any of the following criteria:

- (a) it is expected to be settled in the entity's normal operating cycle;

(b) it is held primarily for the purpose of being traded.

(c) it is due to be settled within twelve months after the reporting date; or

(d) it does not have an unconditional right to defer settlement of the liability for at least twelve months after the reporting date. (Terms of a liability that could, at the option of the counterparty, result in its settlement by the issue of equity instruments do not affect its classification).

Non-current Liabilities: All other liabilities not within the above definition shall be classified as non-current

Net Assets: The residual interest in the assets of the municipality after deducting all its liabilities.

Design Principles

The design principles defined and included in the Item segment Introduction need to be considered together with the following design principle(s):

Principle 1: Cash and Cash Equivalents, Bank Overdraft - Cash comprises cash on hand and demand deposits. Cash equivalents are short-term, highly liquid investments that are readily convertible to known amounts of cash and which are subject to an insignificant risk of changes in value. The municipality need to add the detail based on their unique cash management portfolio being the “posting-level account”. The naming convention indicates both the name of the financial institution and account or reference number. Accounts set at a posting level with GUID's¹ included for municipalities to change the description to the respective account numbers. Accounts within the specific bank accounts are presented by specific accounts by transaction type to reflect the movement in the general ledger between opening and closing balance.

Principle 2: Unallocated Deposits – The account for unallocated deposits consists of deposits made to the municipalities' bank account. Due to a lack of information on the purpose of the deposit, beneficiary information not complete or correct, reference numbers not provided, capacity, timing differences, etc. these transactions could not be recognised as revenue or allocated to a customer account. These transactions must be captured as Unallocated deposits in the Item Liabilities until the amount is identified to be allocated against revenue or assets. Due to the significance of the values involved, lack of control in place over these outstanding items and the VAT implication of these transactions, *mSCOA* provides and account for *municipalities to allocate these transactions. Unallocated Deposits was in Assets*

¹ Globally Unique Identifier (GUID).

but has been moved to *Item Liabilities* in chart 6.3 and are used for the reasons provided above.

Principle 3: Construction Contracts and Receivables - The municipality would be considered the “contractor” if performing construction work pursuant to a construction contract by entering into a contract to build structures, construct facilities, produce goods, or render services to the specifications of another entity. The Standards of GRAP 11 on Construction Contracts need to be applied in accounting for construction contracts.

Principle 4: Current Portion of Non-Current Receivables/ Non-current Receivables – MFMA Circular 8 of 2004 directs on “forbidden loans”. mSCOA provides for accounts dealing with “forbidden loans” not legitimising these actions but correctly recording them for presentation purposes. This account is used for the recording of the current portion of long term receivables being the amounts due within the next 12 months.

Principle 5: Receivables from Non-Exchange Transactions – This account is used for recording amounts receivable due from Non-Exchange Transactions, such as insurance claims, rates and other taxes, subsidies, road reinstatements, and repayments resulting from unauthorised expenditure. Non-Exchange Transactions are transactions that are not exchange transactions. In a non-exchange transaction, an entity either receives value from another entity without directly giving approximately equal value in exchange, or gives value to another entity without directly receiving approximately equal value in exchange.

Principle 6: Operating Lease - Straight Lining - Operating lease receivables whereby the smoothing of an operating lease expense results in a receivable.

Principle 7: Control, Clearing and Interface Accounts (Current Liabilities and/ or Current Assets) – These accounts may have debit or credit balances at the end of the reporting period. This group of accounts are used for the recording of uncleared credit/ debit amounts resulting from control, interface and clearing accounts required by the general ledger system to import transactions/ balances from the sub ledger or other systems such as billing, procurement, asset modules, payroll, electronic funds transfer (EFT) processes, etc. This may be an asset or liability and not to be considered accordingly in preparing financial statements.

Principle 8: Income Tax Receivable, Deferred Tax Assets, Income Tax Payable, Deferred Tax Liabilities - The use of these accounts would be confined to municipal entities registered with SARS for Income Tax Purposes.

Principle 9: Inventory – Inventories are assets: (a) in the form of materials or supplies to be consumed in the production process, (b) in the form of materials or supplies to be consumed or distributed in the rendering of services, (c) held for sale or distribution in the ordinary course

of operations, or (d) in the process of production for sale or distribution. *mSCOA* provides for high-level categories within which the municipality may add detail posting-level accounts. These categories are:

- Agricultural Assets
- Consumable Stores
- Finished Goods
- Materials and Supplies
- Water
- Work-in-progress
- Housing Stock
- Land

Principle 10: Inventory: Water Balance Reporting – To account for Water purchases in accordance with GRAP 12, several MFMA Circulars and the Guideline on Water Balance Reporting issued by the Department of Water and Sanitation serve as the basis for the classification of Water purchases and is incorporated in the inventory classification. The *mSCOA* accounts provides for all the movement analysis as required for the reporting of the Water inventory.

Principle 11: Trade and Other Receivables from Exchange Transactions - Exchange transactions are transactions in which one entity receives assets or services, or has liabilities extinguished, and directly gives approximately equal value (primarily in the form of cash, goods, services, or use of assets) to another entity in exchange. This principle applies to the classification of “receivables” within *mSCOA*. The movement on the various account groups are set-up according to “transaction types” to extract information on the movement from opening balance during the reporting period.

Principle 12: VAT Receivable and Payable – The VAT Modules utilised by the financial system would ultimately determine the detail classification for these accounts. Sufficient detail needs to be available from the financial system to complete the VAT 201 return. The accounts presented in *mSCOA* Version 6.5 is based on specific requests made by vendors and does not support a standardised approach. At the time of finalising this project detail document the outcomes and proposal following the National Treasury/ SARS Workgroup has not been conceptualised and fully documented. The following information requires disclosures on the VAT 201 returns:

- Supply of Goods/ Services

- Standard rate (excluding goods and/ or services and accommodation) net of VAT and VAT amounts.
- Standard rate (only capital goods and/ or services) net of VAT and VAT amounts.
- Zero rate (excluding goods exported) amounts.
- Zero rate (only exported goods) amounts.
- Exempt and non-supplies.
- Supply of accommodation.
- Calculation of Input Tax.
- Capital goods and/ or services supplied to you.
- Capital goods imported to you.
- Other goods and/ or services supplied to you (not capital goods).
- Other goods imported by you (not capital goods).
- Adjustments:
 - Change in use
 - Bad debts
 - Other

Principle 13: Biological Assets - mSCOA provides for the following categories of Biological Assets:

- Dairy Cattle
- Feathered Animals (Eggs and Feathers)
- Forests and Plantations
- Fruit Trees
- Game Animals
- Animals for Reproduction (Cattle, Goats, Sheep and Pigs)
- Animals for Wool or Milk (Goats and Sheep)
- Dogs (Law Enforcement and Working)
- Horses (Law Enforcement and Working)
- Vines
- Plants (Production of Seeds)

Principle 14: Heritage Assets - mSCOA provides for the following categories of heritage assets aligned to the CIDMS Classification Framework:

- Other Heritage Assets:
 - Archives
 - Municipal Jewelry
- Historic Buildings
- Works of Art:
 - Antiques and Collection
 - Paintings
 - Sculptures
 - Works of Art and Collections
- Monuments:
 - Cultural Significant Buildings
 - National Monuments
- Conservation Areas:
 - National Parks

Principle 15: Intangible Assets - mSCOA provides for the following categories of Intangible Assets:

- Intangible Assets under Development
- Capital Development Cost
- Computer Software
- Franchises and Consents
- Incorporation and Organisational Start-up
- Patents, Licenses, Copyrights, Brand Names and Trademarks
- Recipes, Formulae, Prototypes, Design and Models
- Service and Operating Rights (Land Rights)

Principle 16: Property, Plant and Equipment - The Cities Infrastructure Development Management System (CIDMS) provides the bases for the high-level classes used in the mSCOA Tables. National Treasury do take cognisance of the implementation timeframe defined for the implementation of the CIDMS model. However, for purposes of mSCOA the full CIDMS is already applied since mSCOA V6.1 and have been continued to be used in mSCOA V6.7:

- Land

- Transport Assets
- Electrical Infrastructure
- Water supply Infrastructure
- Sanitation Infrastructure
- Solid Waste Infrastructure
- Rails Infrastructure
- Machinery and Equipment
- Furniture and Office Equipment
- Computer Equipment
- Zoos, Marine and Other Non-Biological Assets
- Information and Communication Infrastructure
- Roads Infrastructure
- Storm water Infrastructure
- Community Assets
- Other Assets

Principle 17: Trade and Other Payables Non-Exchange Transactions - Transfers and Subsidies (Unspent) - These accounts are used for the recording of operation and capital transfers received, but unspent at the end of the reporting period. The mSCOA provides for the accounts based on the set-up applied for transfers and subsidies within revenue. The balance maybe receivable or payable at the end of the reporting period. The System Rules provides guidance to the System Developers on the system requirements in this regard.

Principle 18: Trade and Other Payables Non-Exchange Transactions - Transfers and Subsidies (Unspent) National Departments - The classifications provided for under this group of accounts are based on Schedule 4, 6 and 7 of the Division of Revenue Act, 2013 (Act No. 2 of 2013) (DoRA). The content of this classification requires annual updates based on the allocations published in the DoRA for the reporting period.

Principle 19: Trade and Other Payables Non-Exchange Transactions - Transfers and Subsidies (Unspent) Provincial Departments – Initially the Local Government MTREF Allocations 2013/14 Information Sheet was used to populate the categories proposed. This approach has been amended in chart version 6.3. Two main categories for Provincial Grants were created under capital and operational transfers and subsidies namely: Infrastructure and Capacity building. Provincial Government should provide guidance on the format of the reporting required from Municipalities using the specify posting levels. To ensure data

credibility in reporting, the Item Revenue, Liabilities and Funding segment must be aligned and used consistently

Principle 20: Trade and Other Payables Non-Exchange Transactions - Transfers and Subsidies (Unspent) District Municipalities - Limited information is available from the local government database thus the “functional classification” is used for the purpose of classifying district transfers and subsidies to local municipalities in the absence of specific detail.

Principle 21: Trade and Other Payables Non-Exchange Transactions - Transfers and Subsidies (Unspent) (Departmental Agencies, Foreign Government and International Organisations, Households, Non-profit Institutions, Private Enterprises, Public Corporations, Higher Educational Institutions and Parent Municipalities to Municipal Entities) - Limited information is available from the local government database, accordingly” entities” added to these categories are based on the detail defined by the mSCOA for Departments revised for municipalities. Requests for comments to municipalities following the “road shows” (preceding the release of the draft mSCOA regulations) revealed little inputs from municipalities to revise the content of these categories comprising about 70 per cent of the detail populated in this segment. Municipalities are therefore required to request additional information to be considered either during the comments processes following the release of the mSCOA Draft Regulations, or during the formal annual process for requesting changes/ revisions to the mSCOA Technical Committee through the mSCOA Frequently Asked Questions (FAQ) Database.

Principle 22: Reserves and Funds – National Treasury released a Draft Position Paper on Reserves and Funds. Consideration will only be given to add specific accounts if these accounts are provided for by the municipality in a policy and is cash backed. mSCOA provides for the following accounts in this group:

- Compensation for Occupational Injuries and Diseases
- Housing Development Fund
- Revaluation Reserve
- Self-Insurance Reserve
- Capital Replacement Reserve
- Employee Benefit Reserve
- Non-current Provision Reserve
- Valuation Reserve
- Investment in Associates

- Capitalisation Reserve
- Share Premium

Principle 23: Borrowing (Current and Non-current) – Borrowing provides for a classification based on “financial Institution” with a breakdown for defining the account number by the municipality. Provision is made for including detail at a breakdown level by changing the description of the account available in *mSCOA* for this purpose. These accounts do provide a “GUID²” and the “uniqueness” defined in the Local Government Database and Reporting System (LGDRS) by the “municipal code, reporting period and GUID”. If more accounts are needed than provided for currently, a request in this regard need to be made through the *mSCOA* Frequently Asked Questions (FAQ) Database for the *mSCOA* Technical Committee to provide for these in the next *mSCOA* release.

Principle 24: Movement Analysis – Movement analysis was included in *mSCOA* Version 6.1 from “opening” to “closing” balance for the following groups of accounts:

- Provision and Impairment
- Transfers and Subsidies
- Unspent
- Defined Benefit Obligation

Principle 25: Living resources- An additional asset category was created in version 6.7 to cater for living resources as prescribed in terms of GRAP110. *mSCOA* provides for the following accounts in this group:

- Policing and Protection animals
- Zoological plants and animals

Legislative and Regulatory Requirements

For the legislative and regulatory requirements refer to Annexure A of the PSD.

Transactions by Business Process to be allocated in this Segment

Business processes are the set of activities taking place from the initiation of a process to the completion thereof. Typical in the context of financial reporting is a source document from an

activity within a business process initiating the activity to flow through a defined business processes ultimately resulting in the transaction being captured within a financial model in the system and updating the general ledger.

The *mSCOA* classification framework provides a classification structure within the general ledger to “record” transactional information within “fields” within the database functioning in the background of the municipality’s financial application.

Identification of transactions by typical business processes thus would provide a standardisation of specific transactional types for recording within the various segments of *mSCOA*.

The transaction types reflected here are based on the subsequent implementation of the *mSCOA* reform where movement accounting was introduced since version 6.2. This determination was confirmed by the Project Steering Committee during October 2020.

Transaction Type	Allocate Yes/ No	Comments
Net Assets	Yes	
Assets	Yes	
Liabilities	Yes	
Revenue	Yes	
Expenditure	Yes	
Gains and Losses	Yes	

Pending the outcome of the Standard Operating Procedures Project undertaken by the National Treasury: Office of the Accountant General this table may need to be expanded to include business cycles and activities.

Category Links and Business Rules

Category links and business rules refer to programming rules that system developers of financial and business applications for local government are required to provide for in their applications. The considerations listed may not be complete, considering the development

stage of this project and might need to be enhanced as this consultation with the various stakeholder groups evolves.

Proposals that were considered in the design principles of *mSCOA*:

- Transfers and Subsidies Expenditure link to Current Liabilities Transfers and Subsidies Payable.
- Transfers and Subsidies Revenue link to fund and Item: Current Liabilities: Unspent Grants and Fund segment.
- Borrowing link to current and non-current liabilities within the Item Asset /Liabilities.
- Reserves and Funds cash backed link to fund.
- Construction work-in-progress link to project.
- Cash and Cash Equivalents require “accounts to be renamed and the corresponding change” to be made in the Fund segment.
- Bank overdraft placed within current liabilities within the Item Segment structure is included in the discussion. The *mSCOA* is in principle the same account as the bank account, to be reclassified as a non-current liability if in overdraft.
- Opening– is not a transacting posting level, this posting level caters for a balance that rollover from period to period. System requirements on reporting opening balances will be to report annual opening balances and changes to opening balances when applicable due to prior period corrections. This requirement is relevant to:
 - All opening balances in Assets, Liabilities and Net asset accounts.
- The Income Tax Receivable/ Payable accounts are in essence “the same” and all depends on the balance at the reporting date. System requirements need to provide for functionality to be able to relate these accounts and depending on the balance, classify as either a current liability or current asset.
- Impairment and Depreciation dealt with as a “negative asset” in *mSCOA* applicable to:
 - Biological Assets
 - Heritage Assets
 - Intangible Assets
 - Investment Property
 - Property, Plant and Equipment
 - Living resources
- Impairment dealt with as a “negative asset” in *mSCOA* applicable to:

- Property Rates
- Trade and Other Receivable from Exchange Transactions
- Prepayments and Advances

Discussion of the Segment

Assets

The high-level classification for assets provides for the recording of a transaction within the definition of assets as defined in the *Standards of GRAP 1 Presentation of Financial Statements* being “resources controlled by the municipality as a result of past events and from which future economic benefits or service potential are expected to flow to the municipality”.

The next level within the *mSCOA* chart provides for a distinction between current and non-current assets. Guidance on this distinction is available from the *Standards of GRAP 1 Presentation of Financial Statements*.

Current Assets

An asset shall be classified as current when it satisfies any of the following criteria:

- it is expected to be realised in, or is held for sale or consumption in, the municipality’s normal operating cycle;
- it is held primarily for the purpose of being traded.
- it is expected to be realised within twelve months after the reporting date; or
- it is cash or a cash equivalent asset (as defined in the Standard of GRAP on Cash Flow Statements) unless it is restricted from being exchanged or used to settle a liability for at least twelve months after the reporting date.

The illustration below provides the high-level group of accounts included in current assets. This group of accounts consists of multiple posting level accounts for classifying transactions. If the municipality is required to add a further breakdown to define the posting level the context within which these accounts need to be added is discussed as well as the naming convention supporting the account description:



Cash and Cash Equivalents

Definition:

Cash comprises cash on hand and demand deposits. Cash equivalents are short-term highly liquid investments that are readily convertible into known amounts of cash and which are subject to an insignificant risk of change in value.

The *Standards of GRAP 2 on Cash Flow Statements* indicates that the municipality shall disclose the components of cash and cash equivalents and shall present a reconciliation of

the amounts in its cash flow statement with the equivalent items reported in the statement of financial position.

The Municipal Finance Management Act, 2003 (Act No. 56 of 2003) requires the following disclosures:

- in response of each bank account held by the municipality or entity during the relevant financial year, the name of the bank where the account is or was held, and the type of accounts; and
- year-opening and year-end balances in each of these bank accounts.

The account structure within the group for “Cash and Cash Equivalents” consists of the following “non-posting level accounts”:

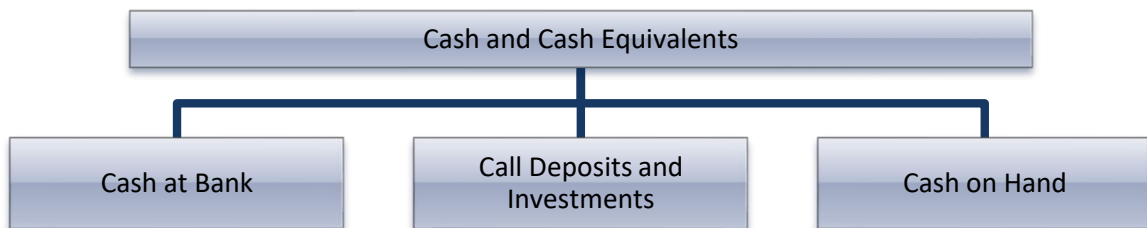

Definitions:

Cash at Bank: This group of accounts include current accounts and savings accounts held at commercial banks (primary and secondary) bank accounts and savings accounts. {Primary Bank account as determined in terms of section 8 of the MFMA}.

Call Deposits and Investments: Investing money with an enterprise with the expectation of earning a return on the investment in the form of interest for a short term usually less than 12 months.

Cash on Hand: Cash held for petty cash, cashier surplus, un-deposited money, etc. Petty Cash

Cash at Bank

Indicated below are the account groups provided for within Cash at Bank. This is a non-posting level. The posting level accounts are set-up within the breakdown structure provided in the classification:

mSCOA Version 6.1 revised the 'breakdown required – request' that was included in the earlier versions of the mSCOA chart. Accounts are provided with description “Specify (replace with account description)”.

The municipality need to change the account description “Specify (Replace with Account Description)” to the Financial Institution and specific account numbers relevant to the municipality:

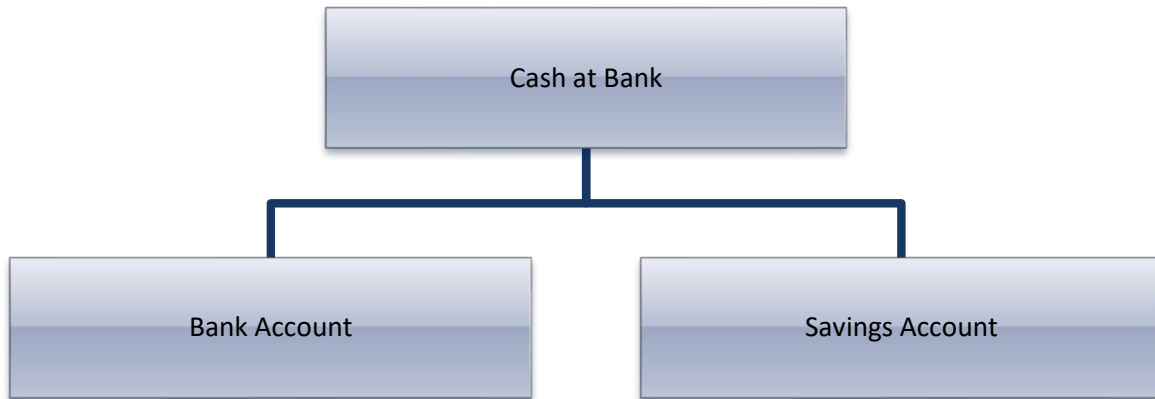

The posting levels are set within the above structure providing for accounts giving a reconciliation from “opening to closing balance”. The opening balance is not a posting level account but an “automated account” rolling the movement in the account forward to the new financial year. However, it should be noted that this account will need to be used for “take-on balance” at initial implementation of *mSCOA*. The movement accounts (excluding opening balance) accounts provides for:

- Deposits
- Withdrawal
- Interest Earned
- Charges

Definitions:

Bank Accounts: This account relates to the cash held in bank accounts and other transactions impacting on the cash held in the bank.

Savings Accounts: These accounts are used for money kept in savings accounts to earn interest on the daily balance.

mSCOA Bank overdraft placed within current liabilities within the Item Segment structure is included in the discussion. The *mSCOA* is in principle the same account as the bank account to be reclassified as a non-current liability if in overdraft. The section dealing with matters to consider in the future on the *mSCOA* chart include an item for further consideration in this regard.

Call Deposits and Investments

Indicated below are the account groups provided for within Cash at Bank. This is a non-posting level. The posting level accounts are set-up within the breakdown structure provided in the classification:

The current mSCOA Version require the 'breakdown where accounts must be specified are provided with the description "Specify (replace with account description)".

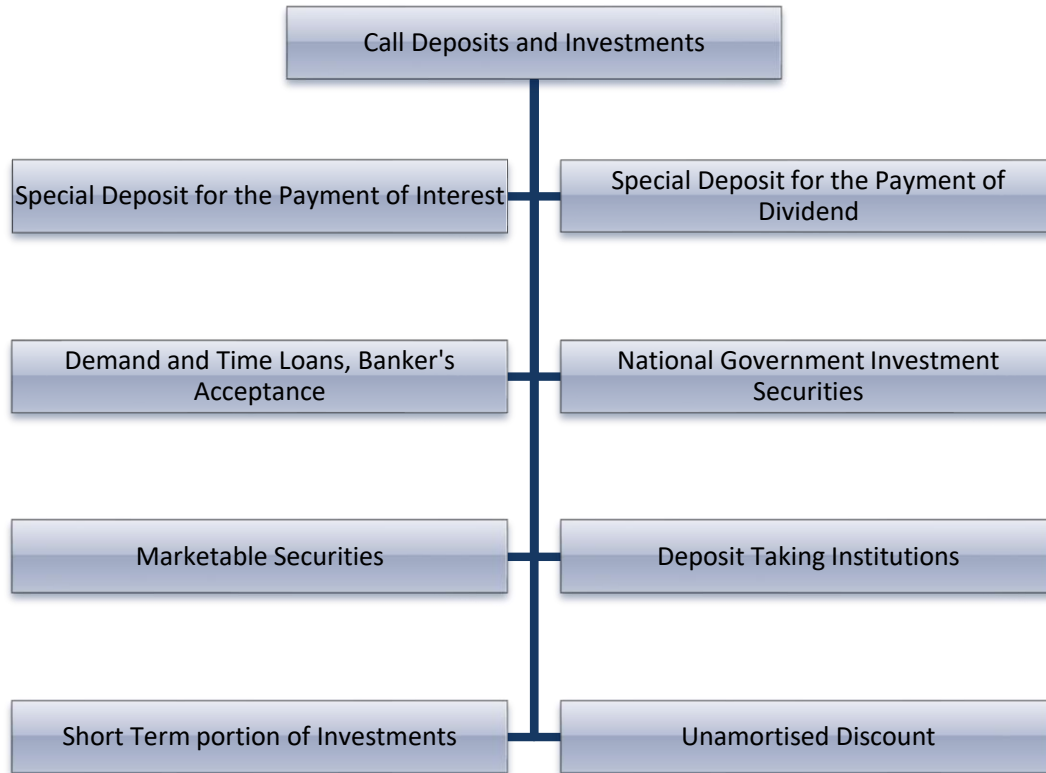

The posting levels are set within the above structure providing for accounts giving a reconciliation from "opening balance". The opening balance is not a posting level account but an "automated account" rolling the closing balance at year-end closure forward to the new financial year. However, it should be noted that this account will need to be used for "take-on balance" at initial implementation of mSCOA. The closing balance account provides for the "movement accounts" including the opening balance to automatically close to this account at year end closure. The closing balance must be rolled forward to the new financial year. The movement accounts (excluding opening and closing balance accounts) provides for:

- Deposits
- Withdrawal
- Interest Earned
- Charges

Definitions:

Special Deposit for the Payment of Interest: This account is used for the recording of accounts specifically used for the payment of interest.

Special Deposit for This account is used for the recording of accounts specifically used for the payment of dividends.

Short-term debt obligations secured by the bank. That is, a bank promises to pay a creditor if a borrower defaults. It is also called a documented discount note.

Transaction record in this account is for security investments issued by National Government in the form of Government Stock or Securities.

Transaction record in this account is for securities/ bonds which could be exchanged in an open market prior to maturity.

Call deposits and investments redeemable within 12 months from the reporting period made at banks and deposit taking institutions.

Short terms portion of non-current investments to be recalled/ available within 12 months after the reporting period.

Unamortised bond discount refers to the difference in the cost to purchase a bond (its market price) and its par or face value. The issuing company can choose to expense the entire amount of the discount or can handle the discount as an asset to be amortised. An amount that has yet to be expenses is referred to as unamortised bond discount.

Construction Contracts and Receivables

Definition:

Amounts due from clients resulting from construction contracts undertaken by the municipality. A Construction contract is a contract or a similar binding arrangement, specifically negotiated for the construction of an asset or a combination of assets that are closely interrelated or interdependent in terms of their design, technology and function or their ultimate purpose or use.

Construction contracts include contracts for the rendering of services which are directly related to the construction of the asset, for example, those for the services of project managers and architects and contracts for the destruction or restoration of assets, and the restoration of the environment following the demolition of assets.

A construction contract may be negotiated for the construction of a single asset such as a bridge, building, dam, pipeline, road, ship or tunnel. A construction contract may also deal with the construction of a number of assets which are closely interrelated or interdependent in terms of their design, technology and function or their ultimate purpose or use. Examples of such contracts include those for the construction of reticulated water supply systems, refineries and other complex infrastructure assets.

The municipality would be considered the “contractor” if performing construction work pursuant to a construction contract by entering into a contract to build structures, construct facilities, produce goods, or render services to the specifications of another entity. The term “contractor” includes a general or prime contractor, a subcontractor to a general contractor, or a construction manager.

	<p><i>How would this be applicable to municipalities?</i></p> <p><i>Example 1</i></p> <p>The district municipality undertaking a capital project for a local municipality, for example building reservoirs. The project will be classified as an operational project in the Project Segment by the district municipality. The recognition of the cost incurred in creating the reservoir is classified as Inventory Work-in-progress (Expenditure)</p>
---	--

Contractors which prepare and present financial statements under the accrual basis of accounting apply the *Standards of GRAP 11 on Construction Contracts* in accounting for construction contracts.

Because of the nature of the activity undertaken in construction contracts, the date at which the contract activity is entered into and the date when the activity is completed usually fall into different reporting periods.

Certain construction contracts entered into by the municipality may not specify an amount of contract revenue. Rather, funding to support the construction activity is provided by an appropriation or similar allocation of general government revenue, or by aid or grant funds. In these cases, the primary issue in accounting for construction contracts is the allocation of construction costs to the reporting period in which the construction work is performed and the recognition of related expenses.



How would this be applicable to municipalities?

Example 2

The municipality may receive an allocation from a provincial department of housing for the housing support programme in terms of which the building or house may be required

Example 3

Various arrangements where the municipality qualify as the “contractor” in the Context of the Standard of GRAP 11 on Construction Contracts are found within the municipal environment, for example housing development on behalf of provincial departments.

The “arrangements” need to be considered in terms of the contractual arrangements and funding agreements to be conclusive on the classification of transactions within the scope of these arrangements. Municipalities are encouraged to bring these arrangements to the attention of National Treasury to assist in defining classification principles and to promote uniform classification within budget and annual reporting.

Accounting for arrangements undertaken in terms of the National Housing Programme may be classified as “Construction Contracts” depending on the conditions of the agreement between the provincial department of housing and the municipality. Usually funds are transferred to the municipality in compensation of the expenditure incurred. These houses get transferred according to the National Housing Programme and thus the municipality does not recognise the asset created as a result of the construction work undertaken.

Construction contracts entered into by the municipality may be established on a commercial basis or a non-commercial full- or partial cost recovery basis. In these cases, the primary issue in accounting for construction contracts is the allocation of both contract revenue and contract costs to the reporting periods in which the construction work is performed.

A contractor engages in contracting activities. Accordingly, buildings constructed by the municipality for itself do not constitute contracting activities. In determining the appropriate

accounting for such items, the entity needs to refer to the *Standards of GRAP 17 on Inventories or Property, Plant and Equipment*.

Contract revenue comprises (a) the initial amount of revenue agreed in the contract; and (b) variations in contract work, claims and incentive payments to the extent that: (i) it is probable that they will result in revenue; and (ii) they are capable of being reliably measured.

Costs that relate directly to a specific contract include:

- site labor costs, including site supervision;
- costs of materials used in construction;
- depreciation of plant and equipment used on the contract;
- costs of moving plant, equipment and materials to and from the contract site;
- costs of hiring plant and equipment;
- costs of design and technical assistance that are directly related to the contract;
- the estimated costs of rectification and guarantee work, including expected warranty costs; and
- claims from third parties.

Costs that may be attributable to contract activity in general and can be allocated to specific contracts include:

- insurance;
- costs of design that are not directly related to a specific contract; and
- construction overheads.

Such costs are allocated using methods that are systematic and rational and are applied consistently to all costs having similar characteristics. The allocation is based on the normal level of construction activity. Construction overheads include costs such as the preparation and processing of construction personnel payroll.

Costs that are specifically chargeable to the customer under the terms of the contract may include some general administration costs and development costs for which reimbursement is specified in the terms of the contract.

Costs that cannot be attributed to contract activity or cannot be allocated to a contract are excluded from the costs of a construction contract. Such costs include:

- general administration costs for which reimbursement is not specified in the contract;
- selling costs;

- research and development costs for which reimbursement is not specified in the contract; and
- depreciation of idle plant and equipment that is not used on a particular contract.

Contract costs include the costs attributable to a contract for the period from the date of securing the contract to the final completion of the contract. However, costs that relate directly to a contract and are incurred in securing the contract are also included as part of the contract costs if they can be separately identified and measured reliably and it is probable that the contract will be obtained. When costs incurred in securing a contract are recognised as an expense in the period in which they are incurred, they are not included in contract costs when the contract is obtained in a subsequent period.

Retentions are amounts of progress billings that are not paid until the satisfaction of conditions specified in the contract for the payment of such amounts or until defects have been rectified. Progress billings are amounts of contract revenue billed for work performed on a contract whether or not they have been paid by the customer. Advances are amounts of contract revenue received by the contractor before the related work is performed.

The municipality presents:

- the gross amount due from customers for contract work as an asset; and
- the gross amount due to customers for contract work as a liability.

The gross amount due from customers for contract work is the net amount of costs incurred plus recognised surpluses; less the sum of recognised deficits and progress billings for all contracts in progress for which costs incurred; plus, recognised surpluses to be recovered by way of contract revenue (less recognised deficits) that exceeds progress billings.

The gross amount due to customers for contract work is the net amount of:

- costs incurred plus recognised surpluses; less
- the sum of recognised deficits and progress billings for all contracts in progress for which progress billings exceed costs incurred, plus recognised surpluses to be recovered by way of contract revenue (less recognised deficits).

Current Portion of Non-Current Receivables/ Non-current Receivables

Definition:

This account is used for recording of the current portion of non-current / long term receivables being the amounts due 12 months from the reporting date. A loan is an arrangement in which a lender gives money to a borrower, and the borrower agrees to repay the money, usually along with interest, at some future point(s) in time. Usually, there is a predetermined time for repaying a loan, and generally the lender has to bear the risk that the borrower may not repay a loan.

This account is used for the recording of the current portion of long term receivables being the amounts due within the next 12 months.

The discussion deals with both current and non-current receivables in the context of the classification framework. The current portion provides for the amount expected to be received within the 12 months following the reporting date and the remainder of the amount outstanding only to be received in periods thereafter.

Section 164(1)(c) of the MFMA (MFMA), relating to forbidden activities states that: “No municipality or municipal entity may make loans to councillors or officials of the municipality, directors or officials of the entity or members of the public.” National Treasury prepared MFMA Circular 8 of 2004 to assist municipalities in legally interpreting section 164(1)(c) of the MFMA and to provide guidance on some specific questions raised by municipalities.

Section 164 commenced on 1 July 2004: No loans may be granted to or taken up by persons mentioned in section 164(1)(c) after 1 July 2004.

Loans granted to or taken up by persons mentioned in section 164(1)(c) before 1 July 2004 remain valid (legal) until the expiry, settlement or termination of such loans.

Policies, practices, agreements or other arrangements, including employment contracts, conditions of employment and collective bargaining agreements, allowing for the granting of loans to, or taking up of loans by persons mentioned in section 164(1)(c) after 1 July 2004 contravene the MFMA and are therefore illegal.

No person mentioned in section 164(1)(c) has a vested right in respect of the granting or taking up of loans after 1 July 2004 notwithstanding the application of such practices, agreements or other arrangements immediately prior to 1 July 2004.

Specifically, an official does not have a vested right to a loan by virtue of his or her conditions of employment. No term or condition of employment can violate an Act of Parliament.

Section 164(1)(c) prohibits a municipality or a municipal entity from making loans to three categories of borrowers:

- councilors or officials of the municipality;
- directors or officials of the municipal entity; and
- members of the public.

The term “councillor” and the term “official” are defined in section 1 of the MFMA. The MFMA does not differentiate between categories of officials and therefore applies to all officials.

Directors of municipal entities refer to the directors of the board of a municipal entity.

In the context of section 164(1)(c), “member of the public” refers to all persons in the community as a whole. This includes both individual members of the public (natural persons) and organisations, associations, bodies corporate or the like (juristic persons). Therefore, a loan to a resident, business, company, non-governmental organisation, sports clubs and the like is not permitted.

The MFMA does not define the term “loan”. A loan, in terms of law, has certain essential elements or characteristics. In essence a loan is the act of making something available to another for a limited period on the understanding that it or its equivalent will be returned.

Two types of loans are possible:

Type 1: in this instance the subject of the loan, such as money, is made available and the ownership passes to the borrower. On expiry or termination of the loan an equivalent object must be returned to the lender. The borrower may be required to return the equivalent or more to the lender. In the case of money, the borrower may be required to pay interest on the money borrowed.

Type 2: in this instance the subject of the loan is made available free of charge and ownership remains with the lender. On expiry or termination of the loan the exact same object, such as a vehicle, must be returned to the lender. If there is a charge it is not considered a loan and may constitute a lease or hire purchase arrangement.

It is important to note that the MFMA distinguishes between the granting of loans on the one hand, and allowances, advances, instalment sales, hire purchase, leases and benefits such as a bursary donation on the other hand.

Municipalities and municipal entities are advised not to disguise the true nature of agreements in order to avoid or circumvent the prohibitions contained in section 164(1)(c). The courts will

consider the true nature and substance of agreements and may regard them as “in fraud of the law”, resulting in the agreement being declared null and void.

If prior to 1 July 2004, the municipality or municipal entity entered into an agreement that, amongst other matters provided for the granting of a loan by the municipality on a future date (after 1 July 2004) or the taking up of a loan by a person mentioned in section 164(1)(c) on a future date, the loan portion of the agreement will be contrary to the MFMA and therefore illegal. Whether or not the entire agreement is illegal or only the loan portion thereof depends on whether the loan portion can be severed from the agreement or not. It will therefore require careful consideration of the entire agreement and may require renegotiation between all parties to resolve corrective action in relation to the offending provision(s).

The basic test for determining whether the loan provision is severable from the agreement is whether the parties intended it to be severable. This will normally require the following to be satisfied:

- the loan provision must be distinct from the rest of the agreement;
- the loan provision must be subsidiary to the main purpose of the agreement such that its elimination would leave the substantial character of the agreement unchanged; and
- the parties would have entered into the agreement even without the loan provision.

Attention is drawn to the requirements of sections 66(f) and 89(b)(vi) of the MFMA which require the accounting officer to report to the municipal council, expenditure on staff benefits (salaries, benefits, and allowances) and entities to report to their parent municipalities on remuneration packages paid to board members and staff. Furthermore, this information must be disclosed in the Annual Report (starting 2003/04) and the Annual Financial Statements (starting 2004/05). In all cases, this will require the reporting of new and existing loans.

The accounting officer of a municipality or municipal entity commits an act of financial misconduct if that person deliberately or negligently contravenes the MFMA. The provision of a loan in contravention of section 164(1)(c) would constitute grounds for financial misconduct.

A municipality or entity is required to investigate allegations of financial misconduct and, where warranted, institute disciplinary proceedings in accordance with the systems and procedures referred to in section 67 and schedules 2 and 3 of the Municipal Systems Act, 2000.

Where appropriate, criminal proceedings may be instituted where a conviction can lead to a fine or imprisonment for a period not exceeding five years.

The accounting officer is required to take all reasonable steps to ensure that the municipality and municipal entity does not engage in forbidden activities as legislated since 1 July 2004.

Policies, practices, agreements or other arrangements, including employment contracts, conditions of employment and collective bargaining agreements, allowing for the granting of loans to, or taking up of loans by persons mentioned in section 164(1)(c) after 1 July 2004 contravene the MFMA and are therefore illegal. Such policies, practices, agreements or other arrangements should be reviewed, renegotiated where necessary and amended as soon as possible to ensure alignment with the MFMA.

In respect of existing policies, practices agreements and other arrangements within the municipality prior to 1 July 2004, municipalities are encouraged to apply the spirit of the legislation and to review all existing loans, which if entered into after 1 July 2004 would have constituted a forbidden activity. Where possible, these loans should be phased-out in an efficient and economical way.

Given the guidance as discussed above, contained in MFMA Circular 8 Forbidden loans, the *mSCOA* does make provision for these forbidden loans due to the reporting requirements in this regard. Furthermore, research indicates that accounts are still in use by municipalities for these types of loans. Whether this might be for “phasing-out” of arrangements prior to 1 July 2004 has not been confirmed.

Posting level accounts available within this group do not require any further breakdown and include:

Receivables from Non-Exchange Transactions:

Current Portion of Non-current Receivables

- 
- Car
 - Computer and Electronic Equipment
 - Housing Selling Schemes
 - Housing
 - Housing Land Sale
 - Sporting and Other Bodies
 - Staff Loan Recoveries
 - Finance Lease Receivable
 - Intercompabny/Parent-subsiidiary Transactions
 - Bursary Obligations
 - Employee Benefits
 - Associates
 - Joint Ventures
 - Subsidiaries
 - Public Organisation
 - Operating Lease

Non-current receivables for the abovementioned accounts also forms part of the chart.

The posting levels is

- Opening balance
- Transfer from Current Assets : This is for the creation of a non-current asset where either long term loans or the restructuring of Debt takes place in the case of payment arrangements.
- Transfer to Current Assets: The portion that is payable in the next 12 months or monthly will be transferred to the Current Assets
- Write -offs
- Impairment:
 - Opening balance,
 - recognised and
 - reversal.

Receivables from Non-Exchange Transactions

Definition:

This account is used for recording amounts receivable due from non-exchange transactions, such as insurance claims, rates and other taxes, subsidies, road reinstatements, repayments resulting from unauthorised expenditure. Non-exchange transactions are transactions that are not exchange transactions.

In a non-exchange transaction, the municipality either receives value from another entity without directly giving approximately equal value in exchange or gives value to another entity without directly receiving approximately equal value in exchange.

mSCOA provides for the following accounts in this group:

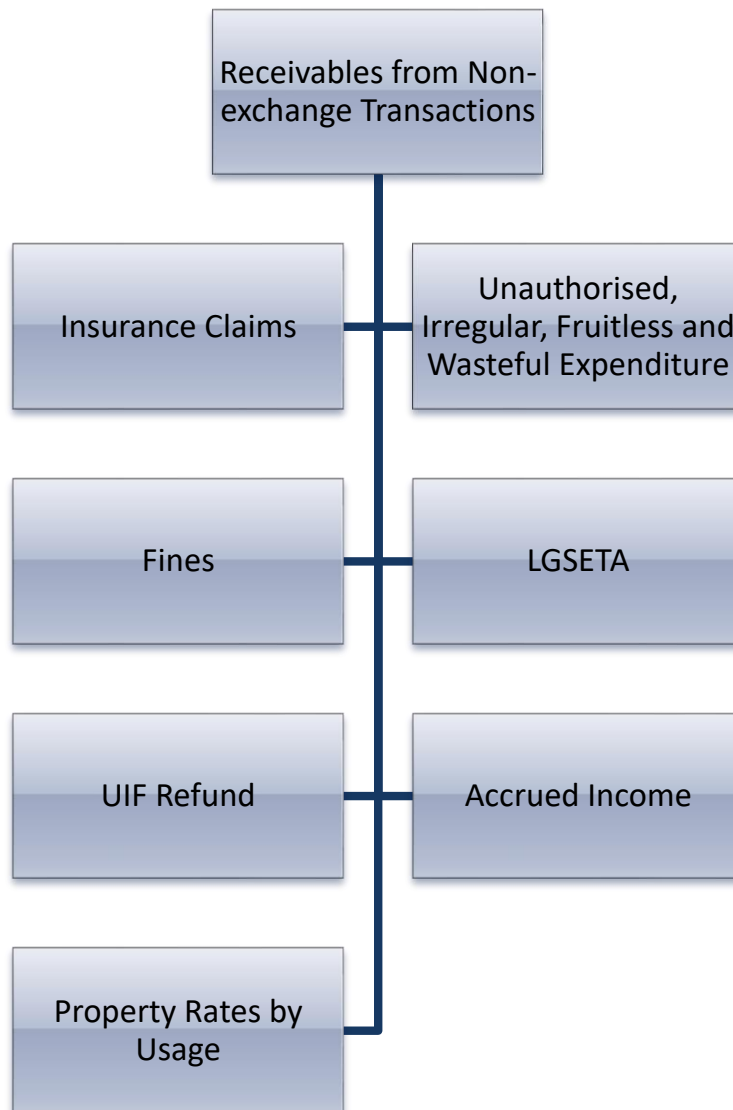

Definitions:

Insurance Claims: Insurance fund settlement/ payment for claims submitted covered in terms of an insurance contract with an insurer.

Property Rates: This account provides for amounts outstanding from rate payers levied in terms of the Municipal Property Rates Act, 2004 as amended.

Property Rates by Usage: This account provides for amounts outstanding from rate payers levied as per section 8(2) of the Municipal Property Rates Amendment Act, 2014.

Unauthorised, Irregular or Fruitless and Wasteful Expenditure: The reporting of expenditure that was incurred as a result of processes and procedures that is in contravention of any legislation or overspending of budget or in contravention of the Supply chain regulations. If a person could be held liable for that expenditure as directed by Section 32 of the Municipal Finance Management Act, 2003, a receivable is created to recover the debt. Debt will be recovered or will remain as unauthorised until it is condoned by council or subsequently written off.

Fines: Receivable from non-exchange transactions recognised under GRAP 23 for receivables raised from fines.

LGSETA : Money received from LGSETA to perform various training initiatives including training for interns.

UIF Refund: Unemployment Insurance Fund (UIF) Refund to councillors for incorrectly deducted from salaries.

Accrued Income: Accrual for miscellaneous non-exchange revenue at the end of the reporting period but not yet invoiced.

Trading Service: These accounts are the control account for the levying of availability charges that is of a non-exchange nature

Electricity

Waste Management

Waste Water Management

Water

Property Rates

The Project Detail Document dealing with the Revenue Segment provides a detail discussion of the set-up of the classification structure in terms of the Municipal Property Rates Act, 2004 as amended.

The control account for the accumulation of debt as a Receivable from Non-exchange transactions for property rates includes the rate payers' control accounts as listed below, not at a posting level.

Property Rates by Usage

The Property Rates Act of 2004 as amended in 2014 guided the introduction of Property rates by usage category for Receivables.

Below find the structure for property rates by usage in terms of Sec 8

- Business and Commercial Properties
- Industrial Properties
- Mining Properties
- Residential Properties
- Agricultural Properties
- Public Benefit Organisations
- Public Service Purposes Properties
- Public Service Infrastructure Properties
- Vacant Land
- Sports clubs and Fields – As approved for Bitou Municipality in terms of the MPRA section 8(4)

Residential sectional title garages – As approved for Drakenstein Municipality in terms of the MPRA section 8(4).

The posting levels below is used for the reporting of receivables that are being billed monthly in accordance with the tariffs as approved by Council.

Posting Level

- *Opening Balance – not a posting level, rollover from period to period to be provided within the system requirements.*
- Monthly Billing - posting level.
- Interest Charges - posting level.
- Prior Period Corrections and Adjustments – posting level.
- Collections – posting level.
- Debt Write-offs – posting level.
- Accued Revenue
- Transfer (to) from Non current Receivables
- Impairment
 - *Opening Balance – not a posting level, rollover from period to period to be provide within the system requirements.*
 - Recognised - posting level.
 - Reversal - posting level.

The posting levels for Unauthorised, Irregular, Fruitless and Wasteful Expenditure (UIF & W) was reviewed to be aligned with the reporting required in terms of the MFMA and the Annual Financial statements.

Unauthorised, Irregular, Fruitless and Wasteful Expenditure

Opening balance as restated

Add: Irregular Expenditure - current

Add: Irregular Expenditure - prior period

Less: Amount recoverable - current

Less: Amount recoverable - prior period

Less: Amount written off - current

Less: Amount written off - prior period

The posting levels for Insurance, Unemployment insurance refunds and LGSETA is

- Opening balance
- Claims

- Refunds received

These posting levels aligns with the use of these accounts

Operating Lease - Straight Line

Definition:

Operating lease receivables whereby the smoothing of an operating lease expense results in a receivable.

Control, Clearing and Interface Accounts

This group of accounts are used for the recording of uncleared credit/ debit amounts resulting from control, interface and clearing accounts required by the general ledger system to import transactions/ balances from sub ledger or other systems such a billing, procurement, asset modules, payroll, EFT (electronic funds transfer) processes, etc. May be an asset or liability and need to be considered accordingly in preparing financial statements.

These accounts are not to be seen as a replacement for traditional suspense accounts. Entries to this account must be automated and be within specific requirements for the system functionalities supporting the financial application to running transaction processing, including dealing with interface related matters from sub-systems and modules.

Transactions reflected in this account must automatically clear without manual interference. In practice the balance at month/ year end may not necessarily be zero due to timing differences.

The posting level detail for Control, Clearing and Interface accounts have been added based on information provided by the pilot municipalities in consultation with their respective system developers. The accounts provided for in *mSCOA* Version 6.1 of the *mSCOA* chart includes the following posting levels:

- Rural Project Labour
- Licensing Redistribution
- Cost Redistribution
- Employee Net Pay and Bond Payment
- Employee Salary Advance Payment
- Deduction in arrear and recovery

- Garnishee Payments
- Fraud Payroll Payments
- Merchandising, Jobbing and Contracts
- Legal Fees
- Accrued Interest
- CPA Vehicle license
- Private telephone calls
- Over/ Under Banking
- Third Party Refunds

Income Tax Receivable/ Payable

Income Tax Receivable provides for South African Normal Company Tax Refund due from SARS and Income Tax Payable as being the amount due to SARS.

The Income Tax Receivable/ Payable accounts are in essence “the same”, all depends on the balance at the reporting date. System requirements need to provide for functionality to be able to relate these accounts and depending on the balance, classify such as either a current liability or current asset.

Inventory

Definition:

Inventories are assets in the form of materials or supplies to be consumed in the production process, in the form of materials or supplies to be consumed or distributed in the rendering of services, held for sale or distribution in the ordinary course of operations, or in the process of production for sale or distribution.

Inventories include goods purchased and held for resale including, for example, merchandise purchased by the municipality and held for resale, or land and other property held for sale. Inventories also include finished goods produced, or work in progress being produced, by the municipality.

Inventories also include materials and supplies awaiting use in the production process and goods purchased or produced by the municipality, which are for distribution to other parties for no charge or for a nominal charge. In a municipality’s inventories, these will relate to the

provision of services. In the case of a service provider, inventories include the costs of the service, for which the municipality has not yet recognised the related revenue.

The *mSCOA* provides for the following classification within this group of accounts:

- Agricultural
- Consumables
- Finished Goods
- Materials and Supplies
- Work-in-progress
- Housing Stock
- Land
- Water

At present the above classifications are posting levels accounts with detail to be added at the discretion of the municipality, except for “water”.

Consumable Stores include, amongst other items unique to a municipality, the following:

- Ammunition and Security
- Batteries
- Brooms and Brushes
- Building and Construction Materials
- Cell Phone Accessories
- Camping Materials
- Corporate Gear
- Crockery and Cutlery
- Disposable Paper and Plastic
- Electrical Supplies
- Farming Supplies
- Fencing Material
- Fertilizer
- Firearm Spares Non-military
- Food and Food Supplies
 - Baby and Special Foods

- Bread and Confectionery
- Eggs and Egg Products
- Fruit and Vegetables
- Groceries
- Meat, Poultry and Fish
- Milk and Milk Products
 - Fuel, Oil and Gas
- Chemicals
- Fuel, Oil and Lubricants
- General Gas
- Household Gas
- Medical Gas
- Gardening Supplies
- Hardware
- Insecticides
- Irrigation Materials
- Laboratory Chemicals
- Laboratory Supplies
 - Learning and Teaching Support Materials
 - Media Collections
 - Books, Magazines and Publications
 - Materials
 - Library, Media Film Material
 - Learning Supporting Materials
 - Consumable Materials
 - Durable Materials
 - School Stationery
 - Text and Prescribed Books
- License Plates
- Linen
- Livestock and Plants for Consumption

- Livestock, Fodder and Animal Feed
- Medical Supplies:
 - Application Sets
 - Artificial Aids
 - Bandages and Dressings
 - Blood Product and Plasma
 - Catheters, Tubes and Urine Bags
 - Contraceptives
 - Crutches
 - Dental Consumables
 - Disposable Nappies
 - First Aid Kits
 - Gloves, Disposables and Sundries
 - Heart Valves and Pacemakers
 - HIV/ AIDS Kits
 - Implantable Sets
 - Intravenous Feeds
 - Occupational Therapy
 - Optical Items and Hearing Aids
 - Orthopedic Artificial Limbs
 - Patient Clothing
 - Radio-isotopes
 - Renal Dialysis
 - Stoma Therapy Requisitions
 - Surgical Consumables
 - Surgical Implant Prosthesis
 - Surgical/ Medical Supplies
 - Sutures, Ligature and Skin Staples
 - Syringes and Needles
 - Therapeutic Requisites
 - Wheelchairs
 - X-ray Consumables

- **Medicine**
 - Animal Medicine
 - Animal Vaccines
 - Antiretroviral Drugs
 - Medicine Medical Depot
 - Medicine Other
 - Medicine Vaccines
 - Oral Contraceptives
 - Tablets, Capsules and Lozenges
 - Needlework and Accessories
 - Notice Boards and Signs
 - Packing Material
 - Painting Material
 - Redistribution Items
 - Road and Construction Supplies
 - Road Signs
 - Seeds and Seedlings
 - Spares and Accessories
 - Sport and Recreational Consumables
 - Stationery and Printing
 - Art Requirements
 - Audio Visual Materials
 - Binding
 - Books, Journals, etc
 - Drawing Materials
 - IT Consumables
 - Magazines and Newspapers
 - Photographic Material
 - Print Cartridges
 - Printing Departmental
 - Printing Paper

- Stationery
 - Toiletries
 - Tube light and Light Bulbs
 - Tires and Tubes
 - Uniform and Protective Clothing
 - Washing and Cleaning Detergent
 - Water
 - Wood and Coal
 - Workplace Decoration
 - Workshop Accessories

The Guideline on Water Balance Reporting issued by the Department of Water and Sanitation was used as the basis for the classification incorporated in the inventory classification. The accounts provided for in the movement analysis is explained in several MFMA Circulars including circular no 93, 94 97 and 107.

The *mSCOA* classification structure provide for the following accounts:

- Opening Balance (not posting level)
- System Input Volume:
 - Water Treatment Works
 - Bulk Purchases
 - Natural Sources
- Authorised Consumption:
 - Billed Authorised Consumption:
 - Free Basic Water
 - Subsidised Water
 - Revenue Water
 - Billed Unmetered Consumption:
 - Free Basic Water
 - Subsidised Water
 - Revenue Water
 - Unbilled Authorised Consumption:
 - Unbilled Metered Consumption

- Unbilled Unmetered Consumption
- Water Losses:
 - Apparent Losses:
 - Unauthorised Consumption
 - Customer Meter Inaccuracies
 - Real Losses:
 - Leakage on Transmission and Distribution Mains
 - Leakage and Overflows at Storage Tanks/Reservoirs
 - Leakage on Service Connections up to the point of Customer Meter
 - Data Transfer and Management Errors
 - Unavoidable Annual Real Losses
 - Non-revenue Water

Trade and Other Receivables from Exchange Transactions

Definition:

Exchange transactions are transactions in which one entity receive assets or services, or has liabilities extinguished, and directly gives approximately equal value (primarily in the form of cash, goods, services, or use of assets) to another entity in exchange.

A current asset resulting from selling goods or services on credit (on account). Invoice terms such as (a) net 30 days or (b) 2/10, n/30 signify that a sale was made on account and was not a cash sale.

Exchange transactions are transactions in which one entity receives assets or services, or has liabilities extinguished, and directly gives approximately equal value (primarily in the form of cash, goods, services, or use of assets) to another entity in exchange.

This group of accounts consists broadly of the following categories with the respective explanations/ definitions:

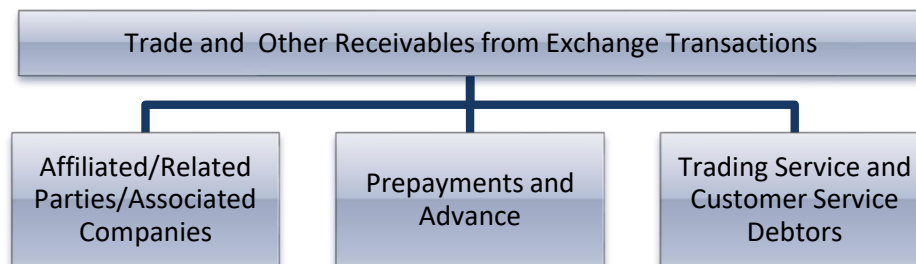

Definitions:

Affiliated/ Related Parties/ Associated Companies: This account should record all receivables due from associated companies carried at costs other than the use of services at arm’s length.

Prepayments and Advances

Pre-payments: are payments in advance for goods and services to be received in future. The actual amount paid is known. A current asset representing amounts paid in advance for future expenses. As the expenses are used or expire, expense is increased, and prepaid expense is decreased.

Trading Service Debtors: This group of accounts is used for debtors from trading services and other services rendered by the municipality.

Affiliated/Related Parties/ Associated Companies

The account for affiliated, related parties and associated companies should only be used for reflecting transactions between the municipality and entities, for example Mangaung Metropolitan Municipality and Centlec for recording inter-entity transactions not at arm's length or on normal business terms available to any other external party to the municipality.

The posting level detail defined within the above category consist of accounts set-up to be able to extract information from the local government data base on the movement in a reporting period from opening to closing balance. The accounts defined for meeting this requirement are:

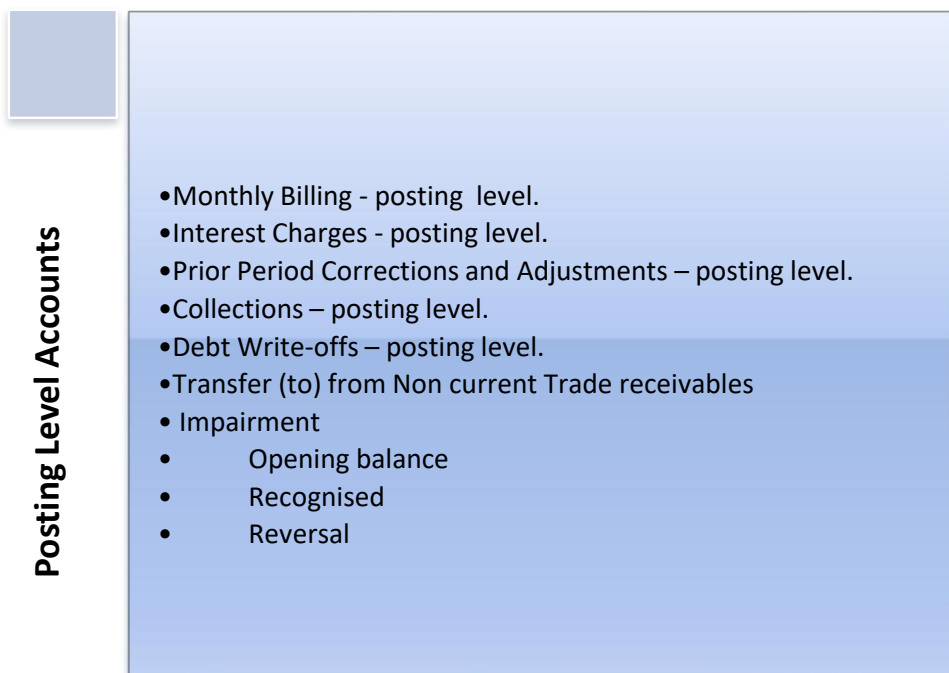

Prepayments and Advances (including Impairment)

Prepayments and Advances (including impairment) includes the following classifications at a non-posting level:

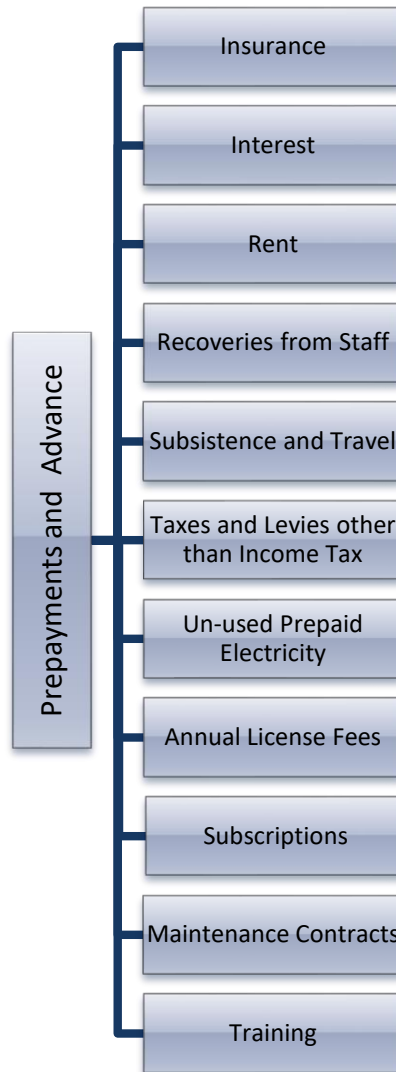

Definitions:

Insurance: This account is used for insurance prepayments paid in advance or at the beginning of the month for the month. Impairment Insurance (Credit Account): Impairment on insurance prepayments.

Interest: This account is used for interest paid in advance. Impairment Interest (Credit Account): Impairment on interest.

Rent: This account is used for rent paid in advance or at the beginning of the month for the month. Impairment Rent: Impairment on rent.

Recoveries of Employee Expenses: Recovery of salary and other advances given to an employee in anticipation of service to be delivered. This is excluded from prohibited loans. The account is used to record amounts given to, for example an employee with the expectation of repayment. If an employee is given money and the money is expected to be repaid or spent for official purposes, the amount will be recorded in this account until it is repaid or until the expense documentation is provided.

Impairment Recoveries of Employee Expenses: Impairment on recoveries of employee expenses.

Subsistence and Travel: The account is used to record amounts given to, for example an employee with the expectation of repayment. If an employee is given money and the money is expected to be repaid or spent for official purposes, the amount will be recorded in this account until it is repaid or until the expense documentation is provided.

Impairment Subsistence and Travel: Impairment on subsistence and travel.

Taxes and Levies other than Income Tax: This account is used for provisional tax payments if applicable. A current asset representing amounts paid in advance for future expenses. As the expenses are used or expire, expense is increased, and prepaid expense is decreased.

Impairment Taxes and Levies other than Income Tax: Impairment on taxes and levies other than income tax.

Un-used Prepaid Electricity: Prepaid electricity sold by year end but not consumed by users.

Impairment Un-Used Prepaid Electricity: Impairment on un-used prepaid electricity.

Annual Licence Fees: This account is used for annual licence fees paid in advance or at the beginning of the month for the month.

Impairment Annual Licence Fees: Impairment of annual licence fees.

Subscriptions: This account is used for subscription fees paid in advance or at the beginning of the month for the month.

Impairment Subscriptions: Impairment on subscriptions.

Maintenance Contracts: This account is used for maintenance contracts paid in advance or at the beginning of the month for the month.

Impairment Maintenance Contracts: Impairment on maintenance contracts.

Training this account is used for training paid in advance or at the beginning of the month for the month. A current asset representing amounts paid in advance for future expenses. As the expenses are used or expire, expense is increased and prepaid expense is decreased.

The posting level detail defined within the above category consist of accounts set-up to be able to extract information from the local government data base on the movement in a reporting period from opening to closing balance. The accounts defined for meeting this requirement are:

Posting Level Accounts

- *Opening Balance – not a posting level, rollover from period to period to be provided within the system requirements.*
- Monthly Billing - posting level.
- Interest Charges - posting level.
- Prior Period Corrections and Adjustments – posting level.
- Collections – posting level.
- Debt Write-offs – posting level.

- Impairment
 - *Opening Balance – not a posting level, rollover from period to period to be provide within the system requirements.*
 - Recognised - posting level.
 - Reversal - posting level.

Impairments accounts are available for each of the posting levels which are at a non-posting level. Impairment accounts provide for movement, where recognised increases impairment and reversal reduce impairment after improvements/ corrective steps was implemented.

A financial asset or a group of financial assets is impaired and impairment losses are incurred if, and only if, there is objective evidence of impairment as a result of one or more events that occurred after the initial recognition of the asset (a 'loss event') and that loss event (or events) has/ have an impact on the estimated future cash flows of the financial asset or group of financial assets that can be reliably estimated. It may not be possible to identify a single, discrete event that caused the impairment, since it may have been the combined effect of several events that did so.

Impairment is dealt with in the *m*SCOA Chart as “negative assets” due to typical financial statement presentation disclosing impairment as a deduction from the asset balance. Important, it is not a set-off against the asset balance. The opening balance accounts are not posting level accounts.

Trading Service and Customer Service Debtors

*m*SCOA provides for detailed accounts per type of service rendered by the municipality. Also, included in this group of accounts in addition to the four main trading services are merchandising, jobbing and contracts, property rental debtors, service charges, housing

selling scheme, water and sanitation service authority, market agency and land sale debtors. These accounts are at a “non-posting level” and the “posting level” is discussed below:

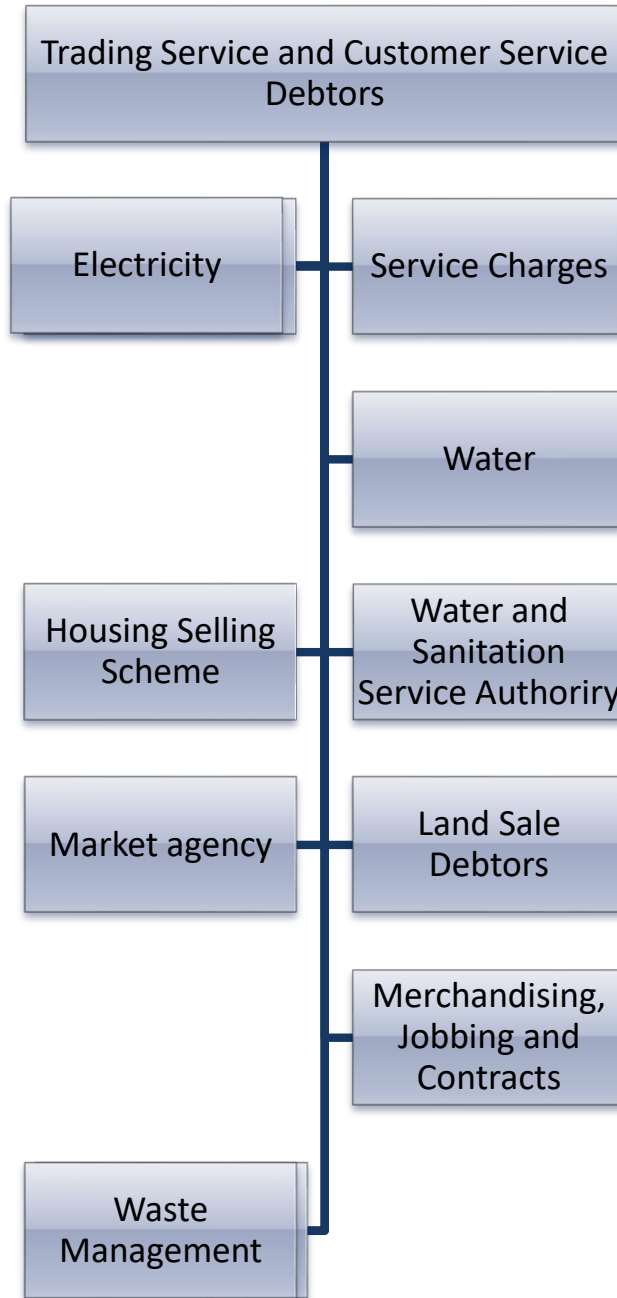

The table below provides a summary of the “type of services” defined in the category with a brief definition/ explanation:

Definitions:

Electricity: This account should record all receivables other than those amounts due from Associated Companies carried at costs receivable for the use of electricity by customers

Merchandising, Jobbing and Contracts: This account should record all receivables other than those amounts due from Associated Companies carried at costs for merchandising, jobbing and contracts.

Property Rental Debtors: This account is to be used for rental dues for letting of municipal property to other entities and the community based on a contractual agreement whether it be for long or short term use.

Service Charges: This account should be used for other services provided by the municipality to the community paid on account, for example cleaning of bushes, grass cutting, replacement of water/ electricity meters, removing of drain blockages, etc.

Waste Management: This account should record all amounts due from customers for waste removal services rendered by the municipality.

Waste Water Management: This account should record all amounts due from water users for waste water management services.

Water: This account should record all amounts due from water users to the municipality.

Housing Selling Scheme: This account should record all amounts due from buyers benefiting from housing selling schemes.

Water and Sanitation Service Authority: Debtor created as a net result of providing water and sanitation function on behalf of the district municipality.

Market Agency: Amounts payable by Buyers at the Market where they purchase in excess of value loaded on the buyer's cards. This is a short-term debt, two to three days as the buyer is not permitted to purchase if they do not settle this debt. Does not go through the billing system, maintained on a separate Market System. Note that municipalities are Agents for the retailers that are renting at the Market.

Land Sale Debtors: This excludes Housing Land Sales. This is for land sold by the municipality, in terms of a sale agreement; the purchaser has to make payment within 30 days of the transfer of the property.

The detail provides for reconciliation on a periodic basis movements required for analytical purposes and benchmarking. The accounts used to provide for the movement on the trading services debtors are:

Account Description	Definition
Opening Balance (not a posting level account)	Opening Balance from prior period pertaining to the specific trading service debtor. Non-posting level, automated for recording the roll forward of the closing balance, at the end of the reporting period to the next period.
Monthly Billings (posting level account)	Monthly billings pertaining to the respective account.
Interest Charge (posting level account)	Interest charges to the respective account.
Prior Period Corrections and Adjustments (posting level account)	Prior period corrections and adjustments pertaining to the respective account.
Collections (posting level account)	Collections made pertaining to the respective account.
Debt Write-offs (posting level account)	Debt Write-offs pertaining to the respective account.
Accrued Revenue (posting level)	Accrual for the respective trading service for service used by consumers at the end of the reporting period but not yet invoiced.
Transfer to(from) Non-Current Asset	Where current assets are transferred to Non-Current Assets or back due to arrangements for debt.

Impairment is dealt with in the *m*SCOA Tables as a “negative assets” due to typical financial statement presentation disclosing impairment as a deduction from the asset balance. Important that this is not a set-off against the asset balance.

Account Description	Definition
Opening Balance (non-posting level)	The opening balance on impairment from previous reporting period. Non-posting level, automated for recording the roll forward of the closing balance at the end of the reporting period

Account Description	Definition
	to the next period. Non-posting level, automated for recording the roll forward of the closing balance at the end of the reporting period to the next period.
Recognised (posting level)	Impairment recognised in surplus and deficit. See gains and losses.
Reversal (posting level)	Reversal of impairment recognised in surplus and deficit. See gains and losses.

Non current Assets: Receivables for Exchange Transactions

When trade debtors enters into a payment arrangement , normally a portion of the outstanding account must be settled immediately and a portion of the outstanding debt is restructured over a longer term. An arrangement is signed and the restructured portion of the debt is transferred to Non-Current receivables for Exchange Transactions.

The chart provides for Trading Service Debtors

- Electricity
- Property Rental Debtors
- Waste water management
- Service charges
- Waste management
- Water

The posting levels in these accounts is

- Opening balance
- Transfer from Current Assets: This the portion of the arrangement that is transferred into the Non-Current Asset
- Transfer to Current Assets: This is the portion that is transferred to the current Asset

VAT Receivable and Payable

Since the inception of VAT in 1991, municipalities were required to register as VAT vendors, and special rules were applicable in respect of supplies by municipalities.

The main difficulties which gave rise to the special rules were that municipal property rates charges were not taxable for VAT purposes and that a profitability or breakeven test was

applied in respect of certain activities to determine whether the suppliers concerned were taxable or not.

These special rules proved to be somewhat complicated and resulted in municipalities having to face significant apportionment difficulties and administrative problems.

Due to these challenges and uncertainties, numerous applications for rulings from tax consultants and municipalities were submitted to SARS requesting clarification of the law. It was therefore proposed in the Minister's Budget Speech in February 2006, that certain changes in regard to the VAT treatment of municipalities be made, including that municipal property rates be zero-rated for VAT purposes with effect from 1 July 2006. The primary objectives of these proposals were:

- to increase the extent of taxable supplies made by municipalities so that municipalities could be treated the same as any other business;
- to unlock the input tax incurred in connection with non-taxable or "out-of-scope" supplies made which could not previously be deducted; and
- to simplify the accounting and tax administration of municipalities.

Various amendments were therefore introduced in the Small Business Tax Amnesty and Amendment of Taxation Laws Act, 2006 to give effect to these objectives.

One of the most important changes was that the VAT law no longer referred to a "local authority", but rather to a "municipality".

The other important change was that charges for municipal property rates became taxable at the zero rate.

These changes to the law came into effect from 1 July 2006.

In addition to the main changes to the law which came into effect from 1 July 2006, it should also be noted that, the receipt of certain payments from government which are made under the annual Division of Revenue Act are subject to VAT at the zero rate with effect from 1 April 2005.

Please refer to the above guide for guidance and clarity on the VAT treatment of supplies made by municipalities from 1 July 2006.

This is provided for in *mSCOA* as informed by the system developers for financial application used by the municipalities and are:

- Current Assets

- VAT Receivable
 - Input tax Accrual
 - Input tax General
 - Input tax Capital
 - VAT Control (Receivable)
- Current Liabilities
 - VAT Control Payable

System requirements for Output and Input Tax Modules would ultimately determine the detail posting-level accounts required for the various financial applications used by the municipalities. Additional Guidance on VAT was provided in the mSCOA Circular no 12. The movement accounting explained must be used to ensure auditability of Input and Output tax.

Deposits

Deposits made by a municipality for fuel, ESKOM, properties, ect.

Non-current Assets

Biological Assets

Definition:

A Biological asset: is a living animal or plant. Biological assets differ from other types of assets as they are used for agricultural purposes, for example the intended use is to actively manage the biological assets' biological transformation.



When would a “biological assets” be classified as property, plant and equipment?

Example 4

Examples where biological assets are not held for agricultural activity (and therefore fall outside the scope of Standards of GRAP 27 on Agriculture) include trees in parks, police horses and dogs, management of biological assets held for research, experimental or public recreational purposes, including raising animals in zoos and game parks.

Version 6.4 provides for this classification as Zoo’s, Marine and Non-Biological Assets within the group of accounts for PPE.

Biological assets or agricultural produce are only recognised when they meet the definition and the recognition criteria. Biological transformation is the process of growth, degeneration, production or procreation that causes qualitative and quantitative changes in a biological asset.

The illustration below summarises the classification structure for biological assets at a non-posting level. The paragraphs to follow discuss the various accounts provided within the overall structure:

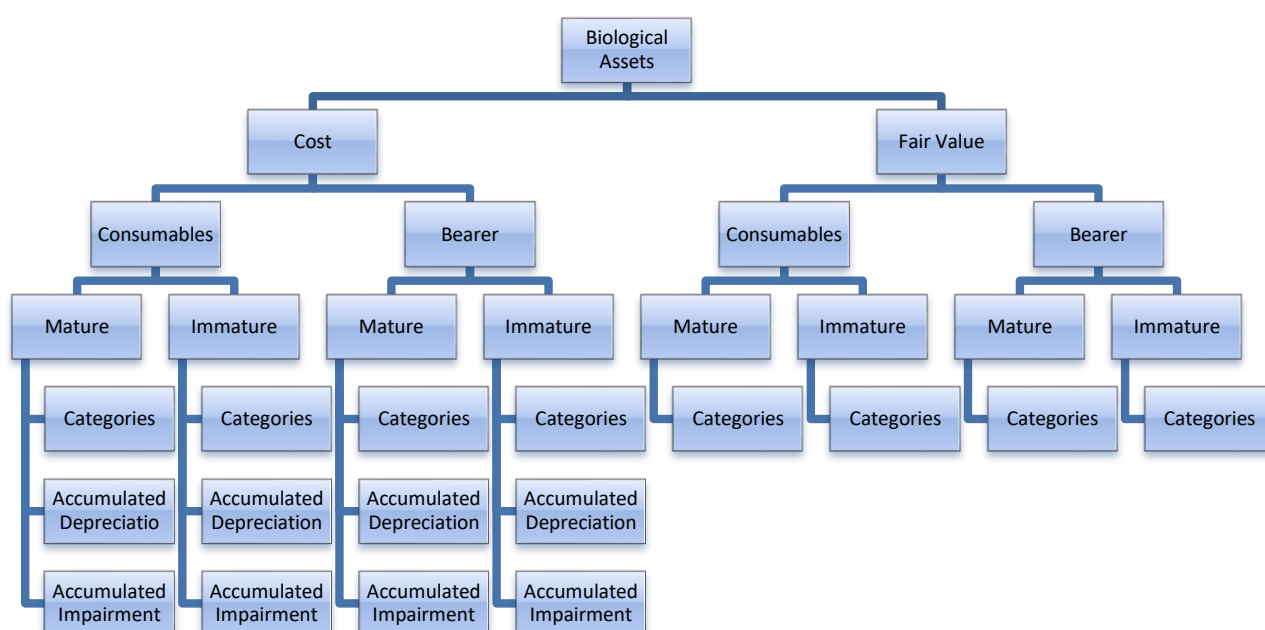

At the highest-level the above categories distinguish between biological assets at cost and fair value.

Definition:

If fair value is not available, a biological asset is to be measured at cost less accumulated depreciation and any accumulated impairment loss. [GRAP 27.32] A biological asset shall be measured on initial recognition and at each reporting date at its fair value less estimated point-of-sale costs, except if fair value is not available. In that case the biological assets are recognised at cost less accumulated depreciation and any accumulated impairment losses. [GRAP 27.14]

Further to the above classification distinction is made between “mature and immature assets”.

Definition:

Mature biological assets are those that have attained harvestable specifications (for consumable biological assets) or are able to sustain regular harvests (for bearer biological assets). Immature biological assets not yet ready for harvesting.

Provided for in the *mSCOA* are the following categories for Biological Assets at a non-posting level:

- Dairy Cattle
- Feathered Animals (Eggs and Feathers)
- Forests and Plantations
- Fruit Trees
- Game Animals
- Animals for Reproduction (Cattle, Goats, Sheep and Pigs)
- Animals for Wool or Milk (Goats and Sheep)
- Dogs (Law Enforcement and Working)
- Horses (Law Enforcement and Working)
- Vines
- Plants (Production of Seeds)

Within the above categories posting-level accounts are provided to classify the movement taking place within these categories in specific accounts. The following detail accounts are provided for in *mSCOA*:

I

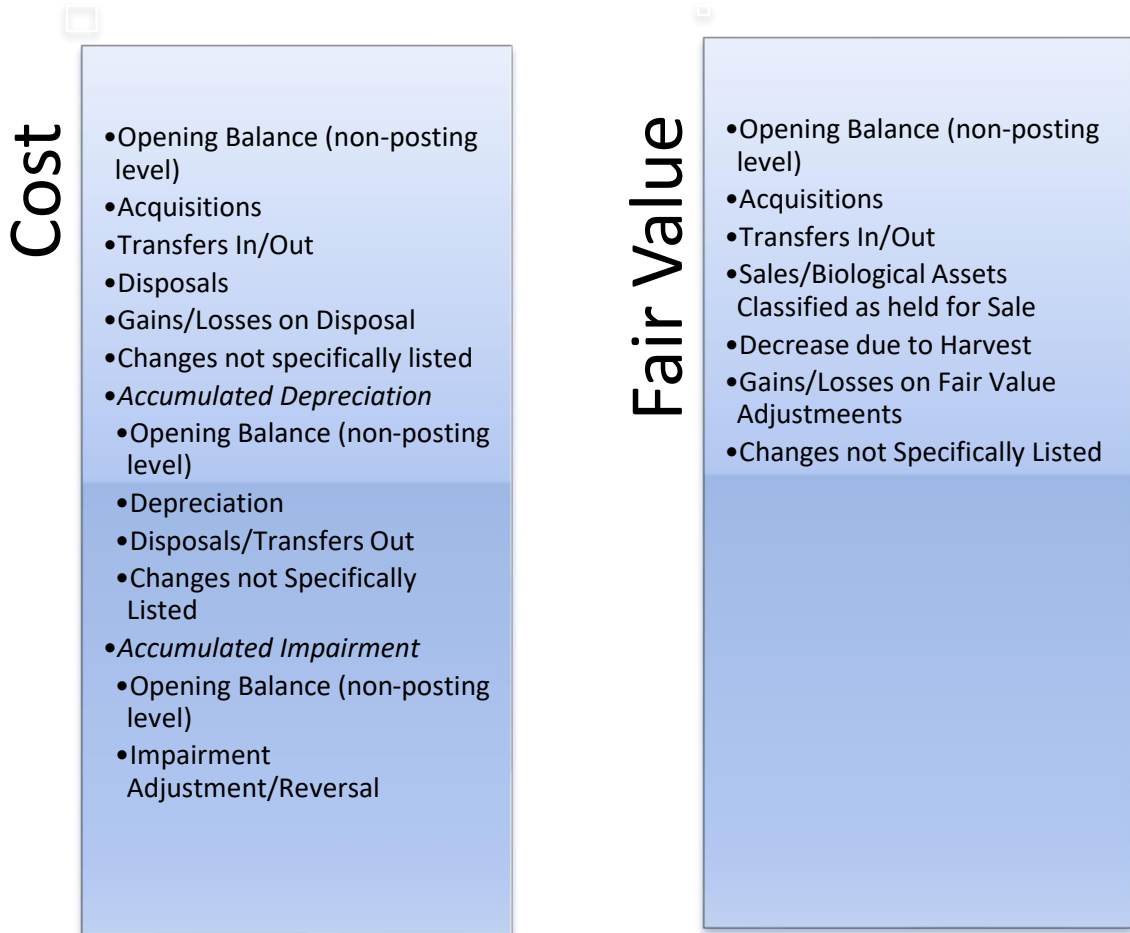

Defined Benefit Assets (Non-current Assets)/ Defined Benefit Obligations (Non-current Liability)

Defined Benefit Assets (Non-current Assets)

In a funded plan, contributions from the employer, and sometimes also from plan members, are invested in a fund towards meeting the benefits.

The future returns on the investments, and the future benefits to be paid, are not known in advance, so there is no guarantee that a given level of contributions will be enough to meet the benefits.

Typically, the contributions to be paid are regularly reviewed in a valuation of the plan's assets and liabilities, carried out by an actuary to ensure that the pension fund will meet future

payment obligations. This means that in a defined benefit pension, investment risk and investment rewards are typically assumed by the sponsor/ employer and not by the individual.

If a plan is not well-funded, the plan sponsor may not have the financial resources to continue funding the plan.

Defined Benefit Asset (Current Assets)

This account should record the unamortised portion of past service costs related to future benefits and pensions which will be expensed in future periods.

Deferred Tax

An asset that may be used to reduce any subsequent period's income tax expense. Deferred tax assets can arise due to net loss carryovers, which are only recorded as assets if it is deemed more likely than not that the asset will be used in future fiscal periods.

Heritage Assets

Definition:

Heritage assets: are assets that have a cultural, environmental, historical, natural, scientific, technological or artistic significance and are held indefinitely for the benefit of present and future generations.



When would an “asset” be classified as heritage assets?

Example 5

Illustrations of the range of assets that can be regarded as classes of heritage assets include the following:

- works of art, antiquities and exhibits such as biological and mineral specimens or technological artifacts;
- collections of insects, butterflies and fossils;
- collections of rare books, manuscripts, records, photographic positives and negatives and other reference material held by libraries to be preserved for their historical and cultural value;
- objects of scientific or technological interest;

	<ul style="list-style-type: none">• historical monuments, such as graves and burial grounds; archaeological and paleontology sites;• conservation areas, such as national parks;• historical buildings that have a significant historical association; movable objects, such as military insignia, medals, coins, stamp collections or objects of decorative or fine art; and• recreational parks used for leisure to be preserved for the benefit of present and future generations.
--	--

A municipality need to choose as its accounting policy either the cost model or the revaluation model and apply that policy to an entire class of heritage assets.

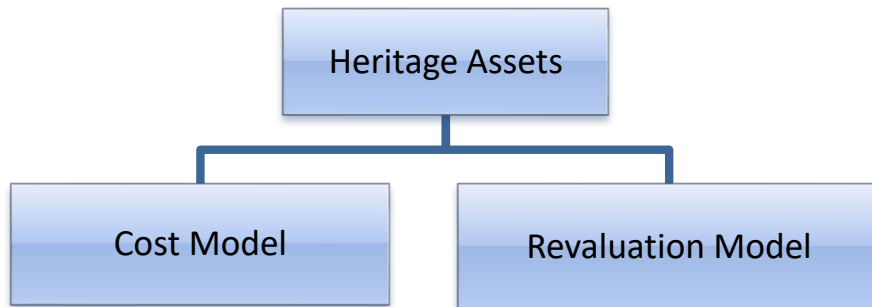

Definition:

Cost model: After recognition as an asset, a class of heritage assets shall be carried at its cost less any accumulated impairment losses.

Revaluation model: After recognition as an asset, a class of heritage assets, whose fair value can be measured reliably, shall be carried at a revalued amount, being its fair value at the date of the revaluation less any subsequent impairment losses. Revaluations shall be made with sufficient regularity to ensure that the carrying amount does not differ materially from what it would be, as determined by using fair value at the reporting date.

The categories provided for in *mSCOA* Version 6.5, aligned to the CIDMS Classification Framework for the classification of heritage assets includes:

Other Heritage Assets:

- Archives
- Municipal Jewelry
- Historic Buildings

Works of Art:

- Antiques and Collection
- Paintings
- Sculptures
- Works of Art and Collections
- Monuments:
 - Cultural Significant Buildings
 - National Monuments
- Conservation Areas:
 - National Parks

The posting level accounts (unless indicated otherwise) defined within the above classification provides for a movement analysis together with the impairment on the respective class.

Cost Model

- Opening Balance (non-posting level)
- Acquisitions
- Change in Accounting Policy
- Disposals
- Transfers Received
- Transfers Made
- Correction of Prior Period Errors
- Accumulated Impairment
- Opening Balance (non-posting level)
- Impairment Adjustment/Reversal
- Disposal
- Transfers Made

Revaluation Model

- Opening Balance (non-posting level)
- Acquisitions
- Change in Accounting Policy
- Disposals
- Increase/decrease in value
- Transfers Received
- Transfers Made
- Correction of Prior Period Errors
- Accumulated Impairment
- Opening Balance (non-posting level)
- Impairment Adjustment/Reversal
- Disposals
- Transfers Made

Intangible Assets

Definition:

Intangible Asset: is an identifiable non-monetary asset without physical substance. In accounting terms, an asset is defined as a resource that is controlled by the municipality and which is expected to provide future economic benefits to it. The *Standards of GRAP 31 Intangible Assets* definition of an intangible asset requires it to be:

- non-monetary,
- without physical substance; and
- Identifiable.



What would an intangible asset be?

Example 6

Examples of intangible assets include:

- Expenditure on advertising, training, start-up, research and development activities. Research and development activities are directed to the development of knowledge. Therefore, although these activities may result in an asset with physical substance (for example a prototype), the physical element of the asset is secondary to its intangible component, for example the knowledge embodied in it.
- In the case of a finance lease, the underlying asset may be either tangible or intangible. After initial recognition, a lessee accounts for an intangible asset held under a finance lease in accordance with this Standard.
- Rights under licensing agreements for items such as motion picture films, video recordings, plays, manuscripts, patents and copyrights are excluded from the scope of the Standard of GRAP on Leases and are within the scope of the Standard on Intangible Assets.
- Entities frequently expend resources, or incur liabilities, on the acquisition, development, maintenance or enhancement of intangible resources such as scientific or technical knowledge, design and implementation of new processes or systems, licences, intellectual property, and trademarks (including brand names and publishing titles). Common examples of items encompassed by these broad headings are computer software, patents, copyrights, motion picture films, customer lists, acquired fishing licences, acquired import quotas, and relationships with customers.
- Not all the items described meet the definition of an intangible asset, for example identifiability, control over a resource and existence of future economic benefits or service potential. If an item within the scope of the Standard of GRAP on Intangible Assets does not meet the definition of an intangible asset, expenditure to acquire it or generate it internally is recognised as an expense when it is incurred

At the highest level *m*SCOA distinguishes between internally generated and other intangible assets.

Definition:

Distinction is made between internally generated intangible assets and otherwise acquired intangibles (other as per the *mSCOA* classification).

At the next level a distinction is made between the cost and revaluation model also at a non-posting level.

Definition:

- **Cost model:** After initial recognition, an intangible asset shall be carried at its cost less any accumulated amortisation and any accumulated impairment losses.
- **Revaluation model:** After initial recognition, an intangible asset shall be carried at a revalued amount, being its fair value at the date of the revaluation less any subsequent accumulated amortisation and any subsequent accumulated impairment losses. For the purpose of revaluations under this Standard, fair value shall be determined by reference to an active market. Revaluations shall be made with such regularity that at the reporting date the carrying amount of the asset does not differ materially from its fair value.



What is the difference between an internally generated and an acquired asset (or other as per the *mSCOA* classification)?

Example 7

- It is important in the application of the *mSCOA* classification tables to recognise the distinction between acquired (other) and internally generated assets. The Standards of GRAP 31 on Intangible assets only allow ACQUIRED intangible assets to be recognised in the Statement of Financial Position.
- This results in what is sometimes described as “internally generated goodwill”. This is the difference between the fair market value of a business and the value of its identifiable net assets per the statement of financial position. The treatment of this goodwill only changes if the entity is acquired, converting the goodwill from internally generated to acquired.
- In the case of a finance lease, the underlying asset may be either tangible or intangible. After initial recognition, a lessee accounts for an

	<p>intangible asset held under a finance lease in accordance with this Standard.</p> <ul style="list-style-type: none">➤ Rights under licensing agreements for items such as motion picture films, video recordings, plays, manuscripts, patents and copyrights are excluded from the scope of the Standard of GRAP on Leases and are within the scope of the Standard on Intangible Assets.➤ Entities frequently expend resources, or incur liabilities, on the acquisition, development, maintenance or enhancement of intangible resources such as scientific or technical knowledge, design and implementation of new processes or systems, licences, intellectual property, and trademarks (including brand names and publishing titles). Common examples of items encompassed by these broad headings are computer software, patents, copyrights, motion picture films, customer lists, acquired fishing licences, acquired import quotas, and relationships with customers.➤ Not all the items described meet the definition of an intangible asset, for example identifiability, control over a resource and existence of future economic benefits or service potential. If an item within the scope of the Standard of GRAP on Intangible Assets does not meet the definition of an intangible asset, expenditure to acquire it or generate it internally is recognised as an expense when it is incurred
--	--

Provided for in *mSCOA* are the following categories following on the classification for “cost or revaluation model” for Intangible Assets at a non-posting level:

- Intangible Assets under Development
- Capital Development
- Computer Software
- Franchises and Consents
- Incorporation and Organisational Start-up
- Patents, Licenses, Copyrights, Brand Names and Trademarks
- Recipes, Formulae, Prototypes, Designs and Models
- Service, Operating and Land Rights

The classification for defining the posting level is within the above categories as illustrated, with the exception of the accounts as indicated not being at the posting level. This posting

level classification is not applicable to Intangible Assets under Development and accordingly this account is at the posting level.

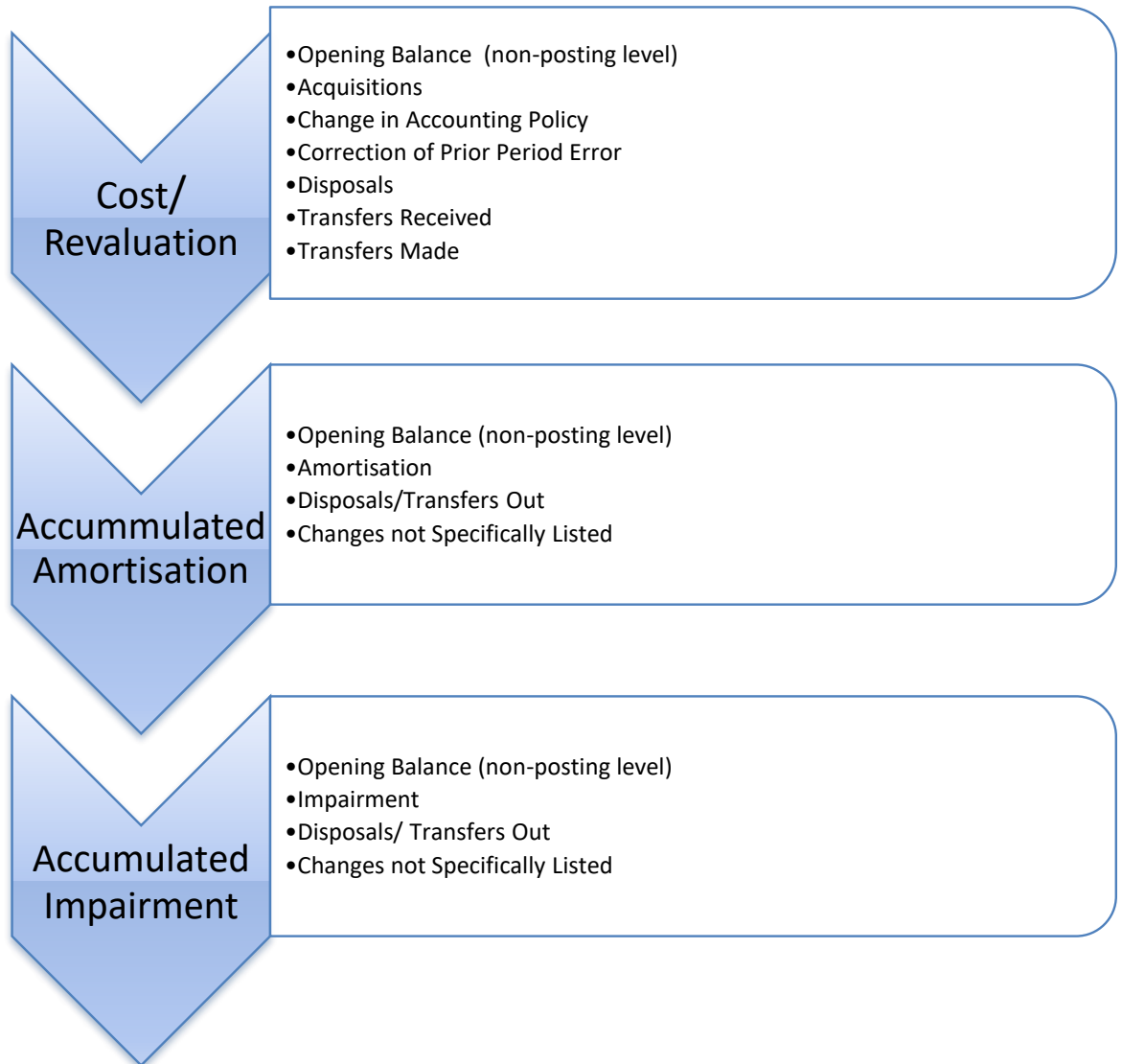

The NERSA Regulatory Reporting Requirements are based on tables BS1/11/13/14. The illustration provides an overview of the classification that meets the NERSA Regulatory Reporting Requirements.

National Treasury and NERSA engaged in a process to reconsider the reporting requirements as well as incorporating the classification to be able to meet the requirements from the Cities Infrastructure Development Management System (CIDMS).

The definition and explanation extracted from the *Regulatory Accounting Manual: Volume 2: Electricity* is included to assist in understanding the requirements. The reference to electric plant per the referenced guidance includes intangible assets but is separated from general

and distribution plant. The account numbers referred to in the definitions also refer to the NERSA account numbers as used in their Regulatory Reporting Table.

Definitions:

Owned and In-use: This account should contain the original cost of electric plant, included in accounts 301 to 499, prescribed herein, owned and in use by the Utility in its electric utility operations, and having an expectation of life in service of more than one year from date of installation, including such property owned by the Utility but held by nominees. [101]

Future Use: This account shall include the original cost of electric plant owned and held for future use in electric service under a definite plan for such use, to include: (1) Property acquired but never used by the utility in electric service, but held for such service in the future under a definite plan and (2) property previously used by the utility in service, but retired or mothballed from such service and held pending its reuse in the future, under a definite plan, in electric service. The property included in this account should be classified in a manner similar to detail in accounts 301 to 499 prescribed for electric plant in service and the account should be maintained in such detail as though the property were in service.

Leased to Others: Electric Plant Leased to Others. This account should record the original cost of electric plant owned by the Utility, but leased to others as operating units or systems, where the lessee has exclusive possession.

Finance Leased: Property under capital leases. This account should contain the amount recorded under capital leases for plant leased from others and used by the Utility in its utility operations. The property included in this account shall be classified according to the detailed accounts (301 – 409) prescribed for electric plant in service and this account shall be maintained in such detail as though the property were used by the owner in its utility operations.

The electric property included in this account shall be classified separately according to the detailed accounts 301 to 499 prescribed for electric plant in service. [102]

Investments in Associate

Definition:

An entity, including an unincorporated entity such as a partnership, over which the investor has significant influence and that is neither a controlled entity nor an interest in a joint venture.

An associate is an entity in which another entity owns a significant portion of voting shares, usually 20–50 per cent. In this case, an owner does not consolidate the associate's financial statements.

Ownership of over 50 per cent creates a subsidiary, with its financial statements being consolidated into the parent's books.

Associate value is reported in the statement of financial position as an asset, the investor's proportional share of the associate's income is reported in the statement of financial performance and dividends from the ownership decrease the value on the statement of financial position.

Investments in Joint Venture

Definition:

A binding agreement whereby two or more parties are committed to undertake an activity that is subject to joint control.

A joint venture is a contractual business undertaking between two or more parties. It is similar to a business partnership, with one key difference: a partnership generally involves an ongoing, long-term business relationship, whereas a joint venture is based on a single business transaction.

Individuals or companies choose to enter joint ventures in order to share strengths, minimise risks, and increase competitive advantages in the marketplace. Joint ventures can be distinct business units (a new business entity may be created for the joint venture) or collaborations between businesses.

In collaboration, for example, a high-technology firm may contract with a manufacturer to bring its idea for a product to market; the former provides the know-how, the latter the means.

Investment Property

Definition:

Property (land or building – or part of building – or both) held by (the owner or by the lessee under a finance lease) to earn rentals or for capital appreciation or both, rather than for:

- use in the production or supply of goods or services or for administrative purposes; or
- sale in the ordinary course of operation.

What is recognised in terms of the *Standards of GRAP 16 on Investment Property*?

Example 8

The following are examples of investment property:

- land held for long-term capital appreciation rather than for short-term sale in the ordinary course of operations. For example, land held by a hospital for capital appreciation which may be sold at a beneficial time in the future;
- land held for a currently undetermined future use. (If an entity has not determined that it will use the land either as owner-occupied property, including occupation to provide services such as those provided by national parks to current and future generations, or for short-term sale in the ordinary course of operations, the land is considered to be held for capital appreciation.);
- a building owned by the entity (or held by the entity under a finance lease) and leased out under one or more operating leases on a commercial basis. For example, a university may own a building that it leases on a commercial basis to external parties;
- a property owned by the entity and leased out at a below market rental; and
- property that is being constructed or developed for future use as investment property.
- The rent earned does not have to be at a commercial basis or market related for the property to be classified as investment property.

What is NOT recognised in terms of the Standards of GRAP 16 on Investment Property?

Example 9

- The following are examples of items that are not investment property and are therefore outside the scope of this Standard:
- Property held for sale in the ordinary course of operations or in the process of construction or development for such sale (see the Standard of GRAP on Inventories). For example, a municipality may routinely supplement rate income by buying and selling property, in which case property held exclusively with a view to subsequent disposal in the near future or for development for resale is classified as inventory. The Department of Housing may routinely sell part of its housing stock in the ordinary course of its operations as a result of changing demographics, in which case any housing stock held for sale is classified as inventory.

- Property being constructed or developed on behalf of third parties. For example, the Department of Housing may enter into construction contracts with entities external to its government (see the Standard of GRAP on Construction Contracts);
- Owner-occupied property (see the Standard of GRAP on Property, Plant and Equipment), including (among other things) property held for future use as owner-occupied property, property held for future development and subsequent use as owner-occupied property, property occupied by employees such as housing for military personnel (whether or not the employees pay rent at market rates) and owner-occupied property awaiting disposal.
- Property that is leased to another entity under a finance lease.
- Property held to provide goods and services and also generates cash inflows. For example, an entity may hold a large housing stock used to provide housing to low income families at below market rental. In this situation, the property is held to provide housing services rather than for rentals or capital appreciation and rental revenue generated is incidental to the purposes for which the property is held. Such property is not considered an “investment property” and would be accounted for in accordance with the Standard of GRAP on Property, Plant and Equipment; and Property held for strategic purposes which would be accounted for in accordance with the Standard of GRAP on Property, Plant and Equipment.
- Some entities hold property to deliver goods and services rather than to earn rental or for capital appreciation. In such situations, the property will not meet the definition of investment property as its main purpose is the delivery of goods and services. This Standard is applicable if the main purpose and most significant use of the property is to earn rental or for capital appreciation. For example, when an entity owns a building, mainly used for the delivery of social housing but rents out a floor of the building to shops, banks and other external parties, the building should be accounted for as property, plant and equipment as its main purpose and most significant use is the provision of social services. This should be the case irrespective of whether the rental earned from the one floor of the building is significant in relation to the rental earned from the remainder of the building.
- In some cases, entities hold some property that includes a portion that is held to earn rentals or for capital appreciation rather than to provide services and another portion that is held for use in the production or supply of goods or services or for administrative purposes. For example, a hospital or a university may own a building, part of which is

used for administrative purposes, and part of which is leased out as apartments on a commercial basis. If these portions could be sold separately (or leased out separately under a finance lease), an entity accounts for the portions separately. If the portions could not be sold separately, the property is investment property only if an insignificant portion is held for use in the production or supply of goods or services or for administrative purposes.

- In some cases, an entity provides ancillary services to the occupants of a property it holds. An entity treats such a property as investment property if the services are insignificant to the arrangement as a whole. An example would be where an entity owns an office building which is held exclusively for rental purposes and rented on a commercial basis and also provides security and maintenance services to the lessees who occupy the building.
- In other cases, the services provided are significant. For example, an entity may own a hostel. The services provided to residents are a significant component of the arrangement as a whole. Therefore, an owner-managed hostel is owner occupied property, rather than investment property because the main purpose and most significant use of the property is the provision of services to residents. It may be difficult to determine whether ancillary services are so significant that a property does not qualify as investment property. For example, an entity which is the owner of a hotel may transfer certain responsibilities to third parties under a management contract. The terms of such contracts vary widely. At one end of the spectrum, the entity's position may, in substance, be that of a passive investor. At the other end of the spectrum, the entity may simply have outsourced day-to-day functions while retaining significant exposure to variation in the cash flows generated by the operations of the hotel.

Investment property should be recognised as an asset when, and only, when it is probable that the future economic benefits or service potential that are associated with the investment property will flow to the entity and the cost or fair value of the investment property can be measured reliably.

At the next level a distinction is made between the cost and the fair value model also at a non-posting level.

Under the cost model assets are carried at cost less any accumulated depreciation and any accumulated impairment losses subsequent to recognition.

Definition:

The municipality shall choose as its accounting policy either the fair value model or the cost model and the municipality shall apply that policy to all of its investment property. Investment property shall be measured initially at its cost (transaction costs shall be included in this initial measurement).

After initial recognition, an entity that chooses the fair value model shall measure all of its investment property at fair value. When a property interest held by a lessee under an operating lease is classified as an investment property the fair value model shall be applied.

With the above categories provision are made for the following posting-level accounts:

Cost Model

- Opening Balance (non-posting level)
- Additions:
 - Direct
 - Subsequent Expenditure
 - Business Combinations
 - Disposals
 - Transfers to/from
 - Other Changes
- Accumulated Depreciation
- Opening Balance (non-posting level)
 - Disposal
 - Transfers to/from
 - Other Changes
- Accumulated Impairment
- Opening Balance (non-posting level)
- Impairment Reversal/Adjustment
- Disposals/Transfers Out
- Changes not Specifically Listed

Fair Value Model

- Opening Balance (non-posting level)
- Additions:
 - Direct
 - Subsequent Expenditure
 - Business Combinations
 - Disposals
 - Fair Value Adjustments
 - Transfers to/from
 - Other Changes
- Transfers to/from

Investment in Subsidiary

Definition:

A subsidiary is one in which another, generally larger, entity, known as the parent, owns all or at least a majority of the shares. As the owner of the subsidiary, the parent may control the activities of the subsidiary.

Investment

Definition:

Assets held primarily for the creation of wealth through receipt of distributions (such as interest, royalties, dividends and rentals), for capital appreciation.

*m*SCOA Version 6.1 revised the ‘breakdown required – request’ included in earlier versions of the *m*SCOA chart. Accounts are provided with description “Specify (replace with account description)”. The municipality needs to change the description to the provide the name of the financial institution with the account number.

Investments

- Bankers’ Acceptance Certificate
- Deposit Taking Institutions
- Bank Repurchase Agreements
- Derivative Financial Assets
- Guaranteed Endowment Policies (Sinking)
- Listed/Unlisted Bonds and Stocks
- Municipal Bonds
- National Government Securities
- Negotiable Certificate of Deposits: Banks
- Unamortised Debt Expense
- Unamortised Preference Share expense
- Interest Rate Swap

Definitions:

Deferred Debits: Prepaid expense (such as insurance, interest, or rent) carried forward as an asset, until the associated service or benefit is received. Also, called deferred asset.

Unamortised Debt Expense: This account should record expenses related to the issuance of debt securities. Amounts recorded in this account should be amortised over the life of each respective issue under a plan which will distribute the amount equitably over the life of the security. The amortisation should be on a monthly basis, and the amount thereof shall be charged to the account for "Short Term Interest and other Interest Expense", or the account for "interest on long-term debt" as appropriate. [NERSA RRM V2: Electricity [180]]

Unamortised Preference Share Expense: This account should record expenses related to the issuance of preference shares. Amounts recorded in this account should be amortised over the life of each respective issue under a plan which will distribute the amount equitably over the life of the security. The amortization should be on a monthly basis, and the amounts thereof should be charged to the account for "Short Term Interest and Other Interest Expense" or the account for "Interest on long-term debt" as appropriate. [NERSA RRM V2: Electricity [181]]

Interest Rate Swaps: interest rate swap is a liquid financial derivative instrument in which two parties agree to exchange interest rate cash flows based on a specified notional amount from a fixed rate to a floating rate (or vice versa) or from one floating rate to another.

Non- current Receivables from Non- exchange transactions

The structure for current receivables have been duplicated here to provide for the non-current portion of these receivables.

Trade and other receivables from Exchange Transactions

The structure includes trading service debtors listed below to cater for the non-current portion of these receivables when arrangement of debt repayment was made.

Electricity

Property Rental Debtors

Waste Water Management

Service charges

Waste management

Water

Operating lease receivable

Operating Lease Receivable: Unamortised balance for straight lining of operational lease payments resulting in a receivable.

Intercompany/Parent Subsidiary Transactions

Intercompany/ Parent-subsidiary Transactions: Long term investment in subsidiary municipal entities and municipalities as a result of transactions between municipalities and their subsidiary municipal entities.

Property, Plant and Equipment

Definition:

Tangible items that are held for use in the production or supply of goods and services, for rental to others, or for administrative purposes and are expected to be used during more than one reporting period.



Assets to be classified as property, plant and equipment?

Example 10

Property, plant and equipment is a major classification on the statement of financial position. Included are land, buildings, leasehold improvements, equipment, furniture, fixtures, transport assets, infrastructure, etc.

mSCOA distinguishes at the highest-level between "owned assets" and assets subjected to financial leases labelled as "leased assets":

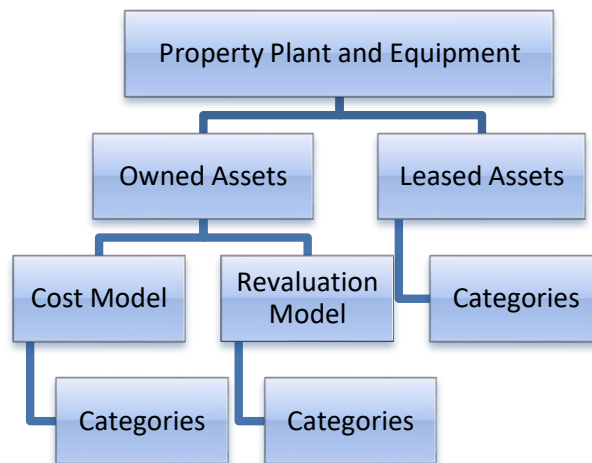

Further distinction is made between cost and revaluation model. All of these accounts are at a non-posting level.

Definitions:

Cost model: After recognition as an asset, an item of property, plant and equipment shall be carried at its cost less any accumulated depreciation and any accumulated impairment losses.

Revaluation model: After recognition as an asset, an item of property, plant and equipment whose fair value can be measured reliably shall be carried at a revalued amount, being its fair value at the date of the revaluation less any subsequent accumulated depreciation and subsequent accumulated impairment losses. Revaluations shall be made with sufficient regularity to ensure that the carrying amount does not differ materially from that which would be determined using fair value at the reporting date.

The categories identified and provided for within the *mSCOA* Table as indicated in the above diagram was initially based on the Local Government Capital Asset Management Framework, SCOA Departments and specific reporting requirements needed by NERSA, Department of Water and Sanitation, Statistics South Africa, South African Reserve Bank and the *Standards of GRAP 17 on Property, Plant and Equipment*.

The cost of an item of property, plant and equipment shall be recognised as an asset if, and only if:

- it is probable that future economic benefits or service potential associated with the item will flow to the municipality, and
- the cost or fair value of the item can be measured reliably.

Spare parts and servicing equipment are usually carried as inventory and recognised in surplus or deficit as consumed. However, major spare parts and stand-by equipment qualify as “property, plant and equipment” when the municipality expects to use them during more than one period. Similarly, if the spare parts and servicing equipment can be used only in connection with an item of property, plant and equipment, they are accounted for as “property, plant and equipment”.

An item of property, plant and equipment that qualifies for recognition as an asset shall be measured at its cost.

The cost of an item of property, plant and equipment comprises:

- Its purchase price, including import duties and non-refundable purchase taxes, after deducting trade discounts and rebates.

- Any costs directly attributable to bringing the asset to the location and condition necessary for it to be capable of operating in the manner intended by management.
- The initial estimate of the costs of dismantling and removing the item and restoring the site on which it is located, the obligation for which an entity incurs costs either when the item is acquired or as a consequence of having used the item during a particular period for purposes other than to produce inventories during that period.

Examples of directly attributable costs are:

- costs of employee benefits arising directly from the construction or acquisition of the item of property, plant and equipment,
- costs of site preparation,
- initial delivery and handling costs,
- installation and assembly costs,
- costs of testing whether the asset is functioning properly, after deducting the net proceeds from selling any items produced while bringing the asset to that location and its condition (such as samples produced when testing equipment), and
- professional fees.

Examples of costs that are not the costs of an item of property, plant and equipment are:

- costs of opening a new facility,
- costs of introducing a new product or service (including costs of advertising and promotional activities),
- costs of conducting business in a new location or with a new class of customers (including costs of staff training), and
- administration and other general overhead costs.

Recognition of costs in the carrying amount of an item of property, plant and equipment ceases when the item is in the location and condition necessary for it to be capable of operating in the manner intended by management. Therefore, costs incurred in using or redeploying an item is not included in the carrying amount of that item. For example, the following costs are not included in the carrying amount of an item of property, plant and equipment:

- costs incurred while an item capable of operating in the manner intended by management has yet to be brought into use or is operated at less than full capacity,
- initial operating losses, such as those incurred while demand for the item's outputs builds up, and

- costs of relocating or re-organising part, or all of the municipality's operations.

Some operations occur in connection with the construction or development of an item of property, plant and equipment, but are not necessary to bring the item to the location and condition required for it to be capable of operating in the manner intended by management.

This incidental operation may occur before or during the construction or development activities. For example, revenue may be earned through using a building site as a car park until construction starts. Because incidental operations are not necessary to bring an item to the location and condition required for it to be capable of operating in the manner intended by management, the revenue and related expenses of incidental operations are recognised in surplus or deficit and included in their respective classifications of revenue and expense.

The municipality shall choose either the cost model or the revaluation model as its accounting policy and shall apply that policy to an entire class of property, plant and equipment.

Revaluation Model

After recognition as an asset, an item of property, plant and equipment whose fair value can be measured reliably shall be carried at a revalue amount, being its fair value at the date of the revaluation less any subsequent accumulated depreciation and subsequent accumulated impairment losses.

Revaluations shall be made with sufficient regularity to ensure that the carrying amount does not differ materially from that which would be determined using fair value at the reporting date.

The fair value of items of land and buildings is usually determined from market-based evidence by appraisal that is normally undertaken by professionally qualified valuers.

The fair value of items of plant and equipment is usually their market value determined by appraisal. For many assets, the fair value will be readily ascertainable by reference to quoted prices in an active and liquid market. For example, current market prices can usually be obtained for land, non-specialised buildings, motor vehicles and many types of plant and equipment.

For some assets, it may be difficult to establish their market value because of the absence of market transactions for these assets. Municipalities may have significant holdings of such assets.

Where no evidence is available to determine the market value of an item of property in an active and liquid market, the fair value of the item may be established by reference to other items with similar characteristics, in similar circumstances and location. For example, the fair

value of vacant land that has been held for a long period during which time there have been few transactions, may be estimated by reference to the market value of land with similar features and topography in a similar location for which market evidence is available.

In the case of specialised buildings and other man-made structures, the municipality may need to estimate fair value using a depreciated replacement cost approach. In many cases, the depreciated replacement cost of an asset can be established by reference to the buying price of a similar asset with similar remaining service potential in an active and liquid market. In some cases, an asset's reproduction cost will be the best indicator of its replacement cost. For example, in the event of loss, a municipal building may be reproduced rather than replaced with alternative accommodation because of its significance to the community.

For items of plant and equipment of a specialised nature, fair value may be based on, for example, either reproduction cost or on depreciated replacement cost.

The depreciated replacement cost of an item of plant or equipment may be established by reference to the market buying price of components used to produce the asset or the indexed price for the same or a similar asset based on a price for a previous period. When the indexed price method is used, judgment is required to determine whether production technology has changed significantly over the period, and whether the capacity of the referenced asset is the same as that of the asset being valued.

The frequency of revaluations depends upon the changes in the fair values of the items of property, plant and equipment being revalued. When the fair value of a revalued asset differs materially from its carrying amount, a further revaluation is required. Some items of property, plant and equipment experience significant and volatile changes in fair value, thus necessitating annual revaluation. Such frequent revaluations are unnecessary for items of property, plant and equipment with only insignificant changes in fair value. Instead, it may be necessary to revalue the item only every three or five years.

When an item of property, plant and equipment is revalued, any accumulated depreciation at the date of the revaluation is treated in one of the following ways:

- restated proportionately with the change in the gross carrying amount of the asset so that the carrying amount of the asset after revaluation equals its revalued amount. This method is often used when an asset is revalued by means of applying an index to its depreciated replacement cost.
- eliminated against the gross carrying amount of the asset and the net amount restated to the revalued amount of the asset. This method is often used for buildings.

The amount of the adjustment arising on the restatement or elimination of accumulated depreciation forms part of the increase or decrease in carrying amount.

If an item of property, plant and equipment is revalued, the entire class of property, plant and equipment to which that asset belongs shall be revalued.

The items within a class of property, plant and equipment are revalued simultaneously to avoid selective revaluation of assets and the reporting of amounts in the financial statements that are a mixture of costs and values as at different dates. However, a class of assets may be revalued on a rolling basis provided revaluation of the class of assets is completed within a short period and provided the revaluations are kept up to date.

If an asset's carrying amount is increased as a result of a revaluation, the increase shall be credited directly to a revaluation surplus. However, the increase shall be recognised in surplus or deficit to the extent that it reverses a revaluation decrease of the same asset previously recognised in surplus or deficit.

If an asset's carrying amount is decreased as a result of a revaluation, the decrease shall be recognised in surplus or deficit. However, the decrease shall be debited directly to a revaluation surplus to the extent of any credit balance existing in the revaluation surplus in respect of that asset.

The revaluation surplus included in net assets in respect of an item of property, plant and equipment may be transferred directly to accumulated surpluses or deficits when the asset is derecognised.

This may involve transferring the whole of the surplus when the asset is retired or disposed of. However, some of the surplus may be transferred as the asset is used by an entity. In such a case, the amount of the surplus transferred would be the difference between depreciation based on the valued carrying amount of the asset and depreciation based on the asset's original cost.

Transfers from revaluation surplus to accumulated surpluses or deficits are not made through surplus or deficit.

NERSA Requirements

The NERSA requirements for the Regulatory Reporting Tables are integrated in the classification structure.

The NERSA Regulatory Reporting Requirements is based on tables BS1/11/13/14. The illustration provides and overview of the classification to meet the NERSA Regulatory Reporting Requirements.

National Treasury and NERSA engaged in a process to reconsider the reporting requirements as well as incorporating the classification to be able to meet the requirements from the Cities Infrastructure Development Management System (CIDMS).

The definition and explanation extracted from the *Regulatory Accounting Manual: Volume 2: Electricity* is included to assist in understanding the requirements. The reference to electric plant per the referenced guidance includes intangible assets but is separated from general and distribution plant. The account numbers referred to in the definitions also refer to the NERSA account numbers as used in the Regulatory Reporting Table.

Definitions:

Owned and In-use: This account should contain the original cost of electric plant, included in accounts 301 to 499, prescribed herein, owned and in use by the municipality/ municipal utility in its electric utility operations, and having an expectation of life in service of more than one year from date of installation, including such property owned by the municipality/ municipal utility but held by nominees. [101]

Future Use: This account shall include the original cost of electric plant owned and held for future use on electric service under a definite plan for such use, to include: (1) Property acquired but never used by the utility in electric service, but held for such service in the future under a definite plan and (2) property previously used by the utility in service, but retired or mothballed from such service and held pending its reuse in the future, under a definite plan, in electric service. The property included in this account should be classified in a manner similar to detail in accounts 301 to 499 prescribed for electric plant in service and the account should be maintained in such detail as though the property were in service.

Leased to Others: Electric Plant Leased to Others. This account should record the original cost of electric plant owned by the municipality/ municipal utility, but leased to others as operating units or systems, where the lessee has exclusive possession.

Finance Leased: Property under capital leases. This account should contain the amount recorded under capital leases for plant leased from others and used by the municipality/municipal utility in its utility operations. The property included in this account shall be classified according to the detailed accounts (301 – 409) prescribed for electric plant in service and this account shall be maintained in such detail as though the property were used by the owner in its utility operations.

The electric property included in this account shall be classified separately according to the detailed accounts 301 to 499 prescribed for electric plant in service. [102]

Classes of Property, Plant and Equipment

A class of property, plant and equipment is a grouping of assets of a similar nature or function in the municipality's operations

The *mSCOA* chart provide for the following detail in the categories to be applied within the above high-level structure as indicated independent of being and owned or leased assets. These accounts are at a non-posting level:

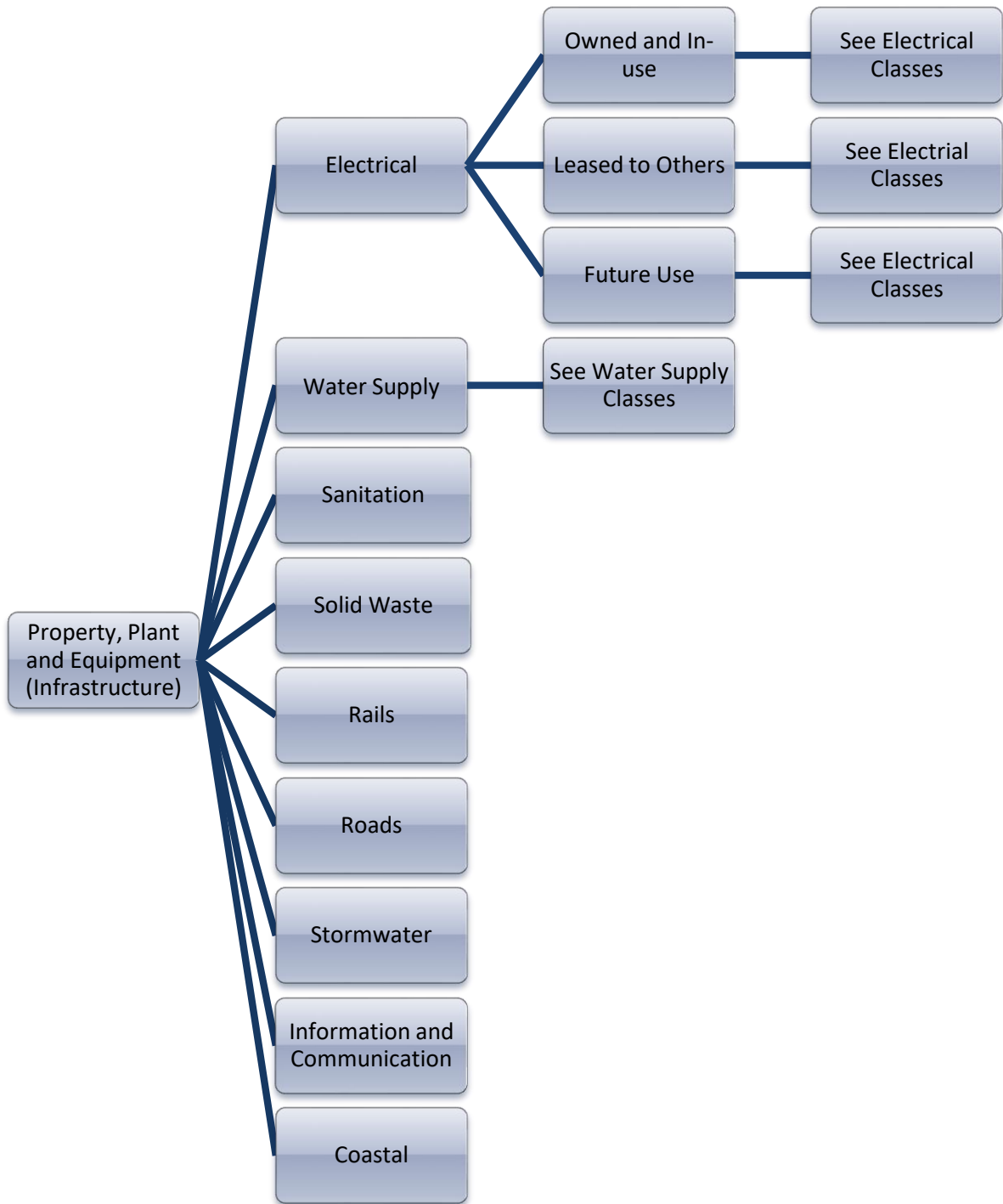

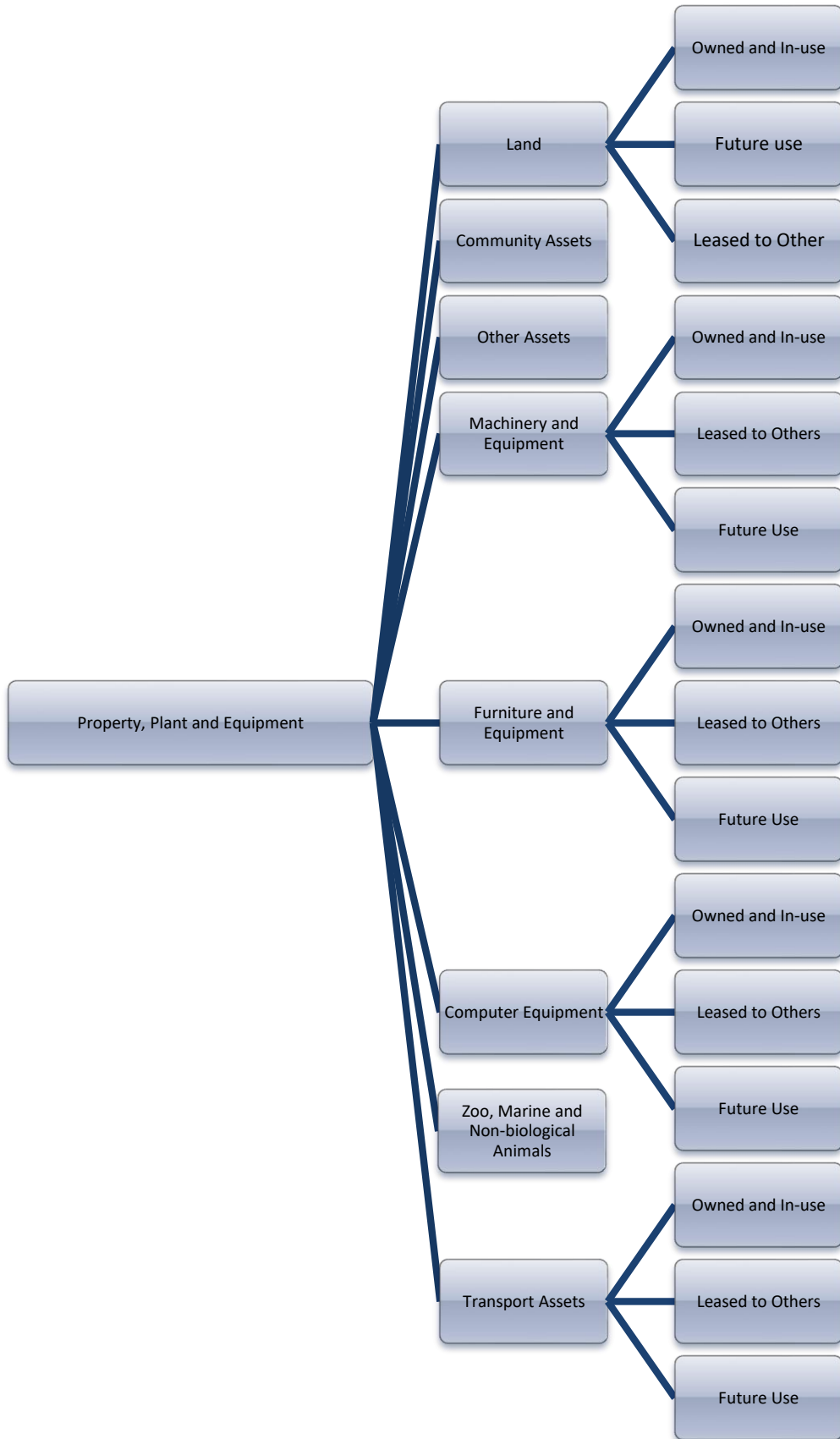

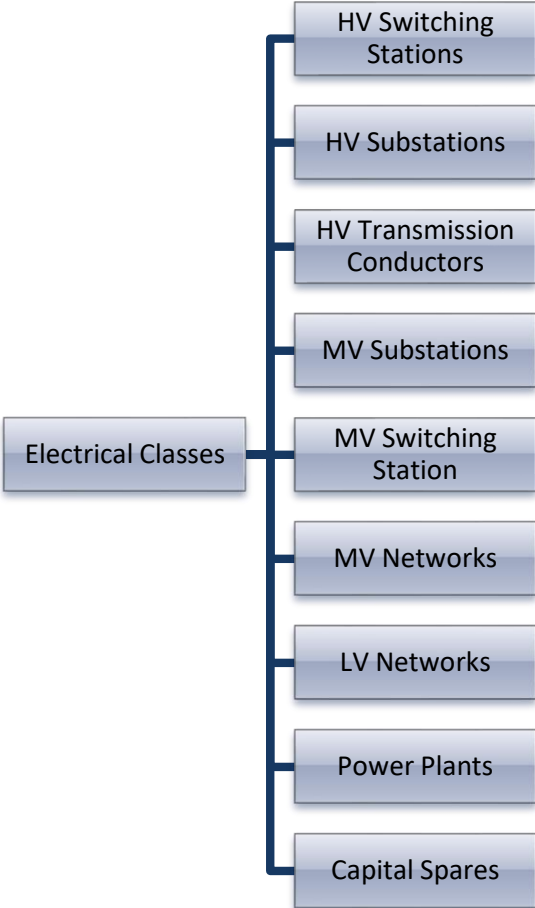

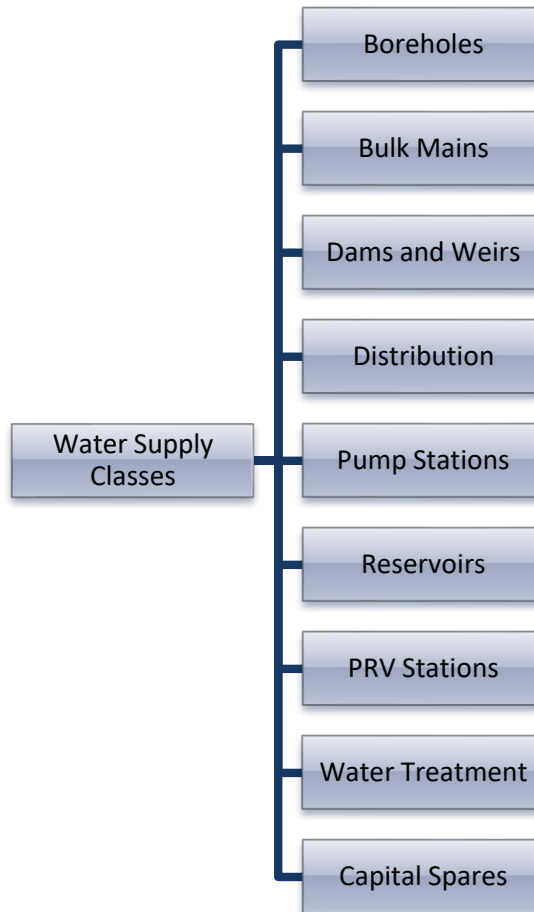

Depreciation and Accumulated Depreciation

Each part of an item of property, plant and equipment with a cost that is significant in relation to the total cost of the item shall be depreciated separately.

The municipality allocates the amount initially recognised in respect of an item of property, plant and equipment to its significant parts and depreciates separately each such part.

A significant part of an item of property, plant and equipment may have a useful life and a depreciation method that are the same as the useful life and the depreciation method of another significant part of that same item. Such parts may be grouped in determining the depreciation charge.

To the extent that the municipality depreciates separately some parts of an item of property, plant and equipment, it also depreciates separately the remainder of the item.

The remainder consists of the parts of the item that are individually not significant. If the municipality has varying expectations for these parts, approximation techniques may be

necessary to depreciate the remainder in a manner that faithfully represents the consumption pattern and/ or useful life of its parts.

The municipality may choose to depreciate separately the parts of an item that do not have a cost that is significant in relation to the total cost of the item.

The depreciation charge for each period shall be recognised in surplus or deficit unless it is included in the carrying amount of another asset.

The depreciation charge for a period is usually recognised in surplus or deficit.

However, sometimes, the future economic benefits or service potential embodied in an asset are absorbed in producing other assets. In this case, the depreciation charge constitutes part of the cost of the other asset and is included in its carrying amount.

Similarly, depreciation of property, plant and equipment used for development activities may be included in the cost of an intangible asset recognised in accordance with the *Standard of GRAP 31 on Intangible Assets*.

The depreciable amount of an asset shall be allocated on a systematic basis over its useful life.

The residual value and the useful life of an asset shall be reviewed at least at each reporting date and, if expectations differ from previous estimates, the change(s) shall be accounted for as a change in an accounting estimate in accordance with the *Standard of GRAP 3 on Accounting Policies, Changes in Accounting Estimates and Errors*.

Depreciation is recognised even if the fair value of the asset exceeds its carrying amount; as long as the asset's residual value does not exceed its carrying amount.

Repair and maintenance of an asset do not negate the need to depreciate it.

The depreciable amount of an asset is determined after deducting its residual value. In practice, the residual value of an asset is often insignificant and therefore immaterial in the calculation of the depreciable amount.

The residual value of an asset may increase to an amount equal to or greater than the asset's carrying amount. If it does, the asset's depreciation charge is zero unless and until its residual value subsequently decreases to an amount below the asset's carrying amount.

Depreciation of an asset begins when it is available for use, for example when it is in the location and condition necessary for it to be capable of operating in the manner intended by management. Depreciation of an asset ceases when the asset is derecognised. Therefore, depreciation does not cease when the asset becomes sidled or is retired from active use and

held for disposal unless the asset is fully depreciated. However, under usage methods of depreciation the depreciation charge can be zero while there is no production.

The future economic benefits or service potential embodied in an asset are consumed principally through its use. However, other factors, such as technical or commercial obsolescence and wear and tear while an asset remains sidled, often result in the diminution of the economic benefits or service potential that might have been obtained from the asset.

Consequently, all the following factors are considered in determining the useful life of an asset:

- expected usage of the asset. Usage is assessed by reference to the asset's expected capacity or physical output.
- expected physical wear and tear, which depends on operational factors such as the number of shifts for which the asset is to be used and the repair and maintenance programme, and the care and maintenance of the asset while idle.
- technical or commercial obsolescence arising from changes or improvements in production, or from a change in the market demand for the product or service output of the asset.
- legal or similar limits on the use of the asset, such as the expiry dates of related leases.

The useful life of an asset is defined in terms of the asset's expected utility to the municipality. The asset management policy of the municipality may involve the disposal of assets after a specified time or after consumption of a specified proportion of the future economic benefits or service potential embodied in the asset. Therefore, the useful life of an asset may be shorter than its economic life. The estimation of the useful life of the asset is a matter of judgement based on the experience of the municipality with similar assets.

Land and buildings are separable assets and are accounted separately, even when they are acquired together. With some exceptions, such as quarries and sites used for landfill, land has an unlimited useful life and therefore is not depreciated. Buildings have a limited useful life and therefore are depreciable assets. An increase in the value of the land on which a building stands does not affect the determination of the depreciable amount of the building.

If the cost of land includes the costs of site dismantlement, removal and restoration, the portion of the land asset is depreciated over the period of benefits or service potential obtained by incurring those costs.

In some cases, the land itself may have a limited useful life, in which case it is depreciated in a manner that reflects the benefits or service potential to be derived from it.

The depreciation method used shall reflect the pattern in which the asset's future economic benefits or service potential are expected to be consumed by the municipality.

The depreciation method applied to an asset shall be reviewed at least at each reporting date and, if there has been a significant change in the expected pattern of consumption of the future economic benefits or service potential embodied in the asset, the method shall be changed to reflect the changed pattern. Such a change shall be accounted for as a change in an accounting estimate in accordance with *Standard of GRAP 3 on Accounting Policies, Changes in Accounting Estimates and Errors*.

A variety of depreciation methods can be used to allocate the depreciable amount of an asset on a systematic basis over its useful life.

These methods include the straight-line method, the diminishing balance method and the units of production method:

- Straight-line depreciation results in a constant change over the useful life; if the asset's residual value does not change.
- The diminishing balance method results in a decreasing change over the useful life.
- The units of production method result in a change based on the expected use or output.

The municipality selects the method that most closely reflects the expected pattern of consumption of the future economic benefits or service potential embodied in the asset. That method is applied consistently from period to period unless there is a change in the expected pattern of consumption of those future economic benefits or service potential.

To determine whether an item of property, plant and equipment is impaired, an entity applies the *Standard of GRAP 21 or 26 on Impairment of Assets*. This Standard of GRAP explains how an entity reviews the carrying amount of its assets, how it determines the recoverable amount or recoverable service amount of an asset and when it recognises, or reverses the recognition of, an impairment loss.

Compensation from third parties for items of property, plant and equipment that were impaired, lost or given up shall be included in surplus or deficit when the compensation becomes receivable.

Impairments or losses of items of property, plant and equipment, related claims for, or payments of compensation from third parties and any subsequent purchase or construction of replacement assets, are separate economic events and are accounted for separately as follows:

- impairments of items of property, plant and equipment are recognised in accordance with the Standard of GRAP 21 or 26 on Impairment of Assets,
- derecognition of items of property, plant and equipment retired or disposed of is determined in accordance with this Standard,
- compensation from third parties for items of property, plant and equipment that were impaired, lost, or given up is included in determining surplus or deficit when it becomes receivable, and
- the cost of items of property, plant and equipment restored, purchased or constructed as replacements is determined in accordance with this Standard.

The carrying amount of an item of property, plant and equipment shall be derecognised:

- on disposal, or
- when no future economic benefits or service potential are expected from its use or disposal.

The gain or loss arising from the recognition of an item of property, plant and equipment shall be included in surplus or deficit when the item is derecognised (unless the *Standard of GRAP 13 on Leases* requires otherwise on a sale and leaseback). Gains shall not be classified as revenue.

The disposal of an item of property, plant and equipment may occur in a variety of ways (for example by sale, by entering into a finance lease or by donation). In determining the date of disposal of an item, an entity applies the criteria in the Standard of GRAP on Revenue from Exchange Transactions, for the purpose of recognising revenue from the sale of goods. The Standard of GRAP 13 on Leases applies to disposal by a sale and leaseback.

If the municipality recognises in the carrying amount of an item of property, plant and equipment the cost of replacement for part of the item, then it derecognises the carrying amount of the replaced part regardless of whether the replaced part had been depreciated separately. If it is not practical for the municipality to determine the carrying amount of the replaced part, it may use the cost of the replacement as an indication of what the cost of the replaced part was at the time it was acquired or constructed.

The gain or loss arising from the derecognition of an item of property, plant and equipment shall be determined as the difference between the net disposal proceeds, if any, and the carrying amount of the item.

The consideration receivable on disposal of an item of property, plant and equipment is recognised initially at its fair value. If payment for the item is deferred, the consideration received is recognised initially at the cash price equivalent. The difference between the

nominal amount of the consideration and the cash price equivalent is recognised as interest revenue in accordance with the Standard of GRAP on Revenue from Exchange Transactions, thus reflecting the effective yield on the receivable.

Assets Acquired and No Cost or Nominal Cost

Where an asset is acquired at no cost, or for a nominal cost, its cost is its fair value as at the date of acquisition.

An item of property, plant and equipment may be gifted or contributed to the municipality. For example, land may be contributed to a municipality by a developer at nil or nominal consideration, to enable the municipality to develop parks, roads and paths in the development.

An asset may also be acquired at nil or nominal consideration through the exercise of powers of sequestration. Under these circumstances the cost of the item is its fair value as at the date it is acquired.

The measurement at recognition of an item of property, plant and equipment, acquired at nil or nominal cost, at its fair value does not constitute a revaluation. Accordingly, the revaluation requirements only apply where the municipality elects to revalue an item of property, plant and equipment in subsequent reporting periods.

Infrastructure Assets

Some assets are commonly described as “infrastructure assets”. While there is no universally accepted definition of infrastructure assets, these assets usually display some or all of the following characteristics:

- they are part of a system or network,
- they are specialised in nature and do not have alternative uses,
- they are immovable, and
- they may be subject to constraints on disposal.

Infrastructure assets meet the definition of property, plant and equipment and shall be accounted for in accordance with the above-mentioned Standard. Examples of infrastructure assets include road networks, sewer systems, water and power supply systems and communication networks.

Leased Property, Plant and Equipment

The *Standard of GRAP 13 on Leases* prescribe for lessees and lessors the appropriate accounting policies and disclosures to apply in relation to finance and operating leases

Initial recognition

At the commencement of the lease term, lessees shall recognise finance leases as assets and liabilities in their statement of financial position at amounts equal to the fair value of the leased property or, if lower, the present value of the minimum lease payments, each determined at the inception of the lease. The discount rate to be used in calculating the present value of the minimum lease payments is the interest rate implicit in the lease, if this is the determining practice, if not, the lessee's incremental borrowing rate shall be used. Any initial direct costs of the lessee are added to the amount recognised as an asset.

Transactions and other events are accounted for and presented in accordance with their substance and financial reality and not merely with legal form. Although the legal form of a lease agreement is that the lessee may acquire no legal title to the leased asset, in the case of finance leases, the substance and financial reality are that the lessee acquires the economic benefits or service potential of the use of the leased asset for the major part of its economic life in return for entering into an obligation to pay for that right an amount approximating, at the inception of the lease, the fair value of the asset and the related finance charge.

If such lease transactions are not reflected in the lessee's financial statements, the assets and liabilities of the municipality are understated, thereby distorting financial ratios.

Therefore, it is appropriate for a finance lease to be recognised in the lessee's financial statements both as an asset and as an obligation to pay future lease payments.

At the commencement of the lease term, the asset and the liability for future lease payments are recognised in the financial statements at the same amounts except for any initial direct costs of the lessee that are added to the amount recognised as an asset.

It is not appropriate for the liabilities for leased assets to be presented in the financial statements as a deduction from the leased assets.

Initial direct costs are often incurred in connection with specific leasing activities, such as negotiating and securing leasing arrangements. The costs identified as directly attributable to activities performed by the lessee for a finance lease are added to the amount recognised as an asset.

Depreciation and Accumulated Depreciation

A finance lease gives rise to a depreciation expense for depreciable assets as well as finance expense for each accounting period. The depreciation policy for depreciable leased assets shall be consistent with that for depreciable assets that are owned, and the depreciation recognised shall be calculated in accordance with the Standard of GRAP on Property, Plant and Equipment and the International Accounting Standard on Intangible Assets.

If there is no reasonable certainty that the lessee will obtain ownership by the end of the lease term, the asset shall be fully depreciated over the shorter of the lease term and its useful life.

The depreciable amount of a leased asset is allocated to each accounting period during the period of expected use on a systematic basis consistent with the depreciation policy the lessee adopts for depreciable assets that are owned. If there is reasonable certainty that the lessee will obtain ownership by the end of the lease term, the period of expected use is the useful life of the asset; otherwise the asset is depreciated over the shorter of the lease term and its useful life.

The sum of the depreciation expense for the asset and the finance expense for the period is rarely the same as the lease payments payable for the period, and it is, therefore, inappropriate simply to recognise the lease payments payable as an expense. Accordingly, the asset and the related liability are unlikely to be equal in amount after the commencement of the lease term.

Impairment

To determine whether a leased asset has become impaired, the municipality applies the *Standard of GRAP 21 or 26 on Impairment of Assets*.

Classes of Property, Plant and Equipment

Lessees shall, in addition to meeting the requirements of the *Standard of GRAP 104 on Financial Instruments* make amongst other requirements the following disclosures for finance leases: “for each class of asset, the net carrying amount at the reporting date”.

Standard of GRAP 13 Leases does not define “for each class of asset” therefore, some classes are defined in the *mSCOA* for “owned” property, plant and equipment.

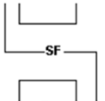
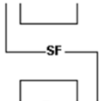
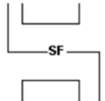
		
<p>Cost Model</p> <ul style="list-style-type: none"> •Opening balance (Non-posting Level) •Acquisitions •Revaluations •Decommissioning, Restoration and Similar Liabilities •Correction of Error •Change in Accounting Policy •Disposals •Transfers Received •Transfers Made <ul style="list-style-type: none"> •Accumulated Depreciation (Not applicable to Land) •Opening Balance (Non-posting) •Other Charges •Depreciation •Disposals •Transfers <ul style="list-style-type: none"> •Accumulated Impairment •Opening Balance (Non-posting level) •Impairment •Disposals/Transfers Out •Changes not specifically Listed 	<p>Revaluation Model</p> <ul style="list-style-type: none"> •Opening Balance (Non-posting level) •Acquisitions •Revaluations •Decommissioning, Restoration and Similar Liabilities •Correction of Error •Change in Accounting Policy •Disposals •Transfers Received •Transfers Made <ul style="list-style-type: none"> •Accumulated Depreciation (No applicable to Land) •Opening Balance (non-posting) •Other Charges •Depreciation •Disposals •Transfers <ul style="list-style-type: none"> •Accumulated Impairment •Opening Balance (Non-posting level) •Impairment •Disposals/Transfers Out •Changes not specifically Listed 	<p>Leased Assets</p> <ul style="list-style-type: none"> •Opening balance (Non-posting Level) •Acquisitions •Revaluations •Decommissioning, Restoration and Similar Liabilities •Correction of Error •Change in Accounting Policy •Disposals •Transfers Received •Transfers Made <ul style="list-style-type: none"> •Accumulated Depreciation (Not applicable to Land) •Opening Balance (Non-posting) •Other Charges •Depreciation •Disposals •Transfers <ul style="list-style-type: none"> •Accumulated Impairment •Opening Balance (Non-posting level) •Impairment •Disposals/Transfers Out •Changes not specifically Listed

Construction Work-in-progress

The cost of a self-constructed asset is determined using the same principles as for -an acquired asset. If an entity makes similar assets for sale in the normal course of business, the cost of the asset is usually the same as the cost of constructing an asset for sale (see the *Standard of GRAP 12 on Inventories*). Therefore, any internal surpluses are eliminated in arriving at such costs.

Similarly, the cost of abnormal amounts of wasted material, labour or other resources incurred in self-constructing an asset is not included in the cost of the asset.

The Project Segment Specifically Capital Projects provide the detail on the composition of the balance accumulated on this account.

The classification structure provided in *mSCOA* chart Version 6.4 includes a movement analysis to reconcile Construction Work-in-progress.

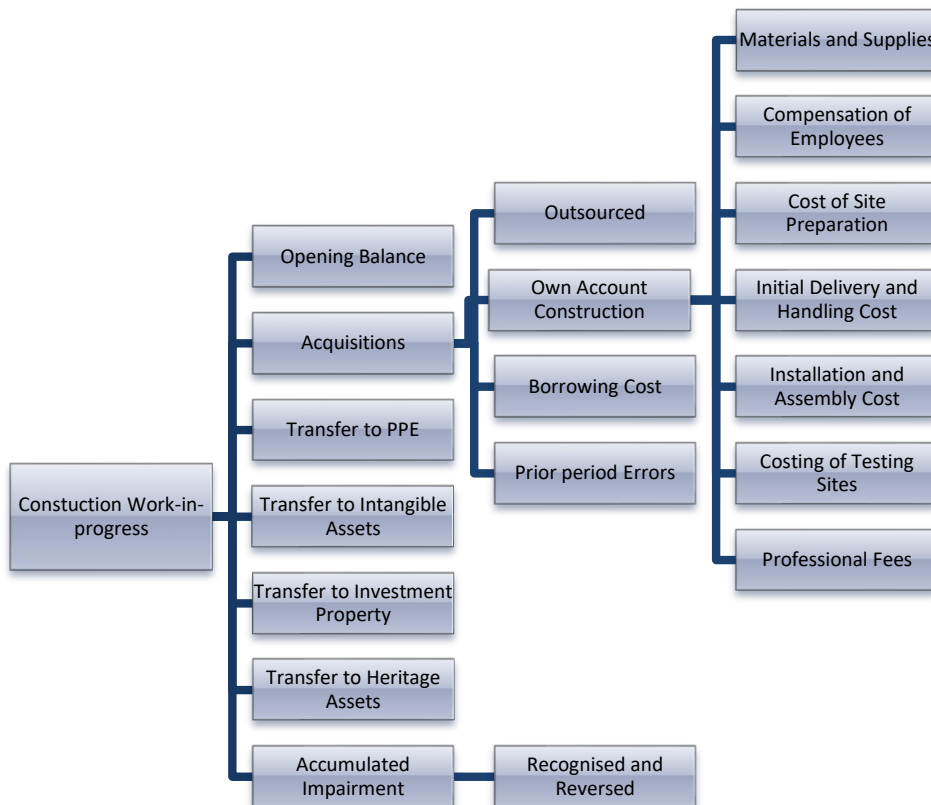

Living resources

Definition:

Living resources include living organisms for example animals and plants that are used or held for: the delivery or provision of goods and services.

Research;

Conservation;

Recreation; agricultural activities;

Education and training and

Rehabilitation or breeding purposes

Living resources

The reporting of living and non-living resources is introduced through GRAP 110.

Only living resources are included in the *m*SCOA under cost and revaluation method for mature and immature animals and accumulated depreciation as well as impairment are provided for.

Living resources shall be recognised as an asset if and are only if:

(a) it is probable that future economic benefits of service potential associated with the asset will flow to the entity; and

(b) the cost or fair of the asset can be measured reliably.

Biological transformation is the process of growth, degeneration, production; and procreation that causes qualitative and quantitative changes in a living resource.

The illustration below summarises the classification structure for living resources at a non-posting level. The paragraphs to follow discuss the various accounts provided within the overall structure:

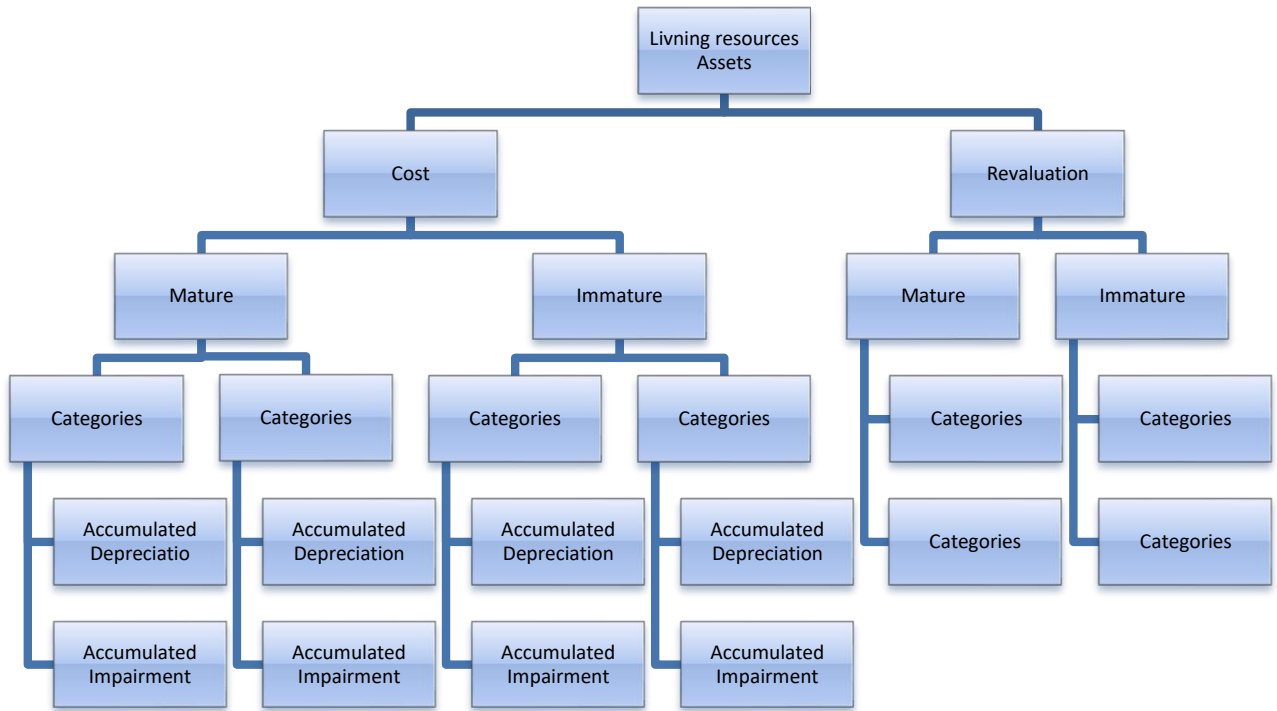

At the highest-level the above categories distinguish between living resources at cost and revaluation.

Definition:

Cost Model: After recognition as an asset, a group of living resources shall be carried at cost less any accumulated depreciation and any accumulated impairment losses. [GRAP110.48]

Revaluation model: After recognition as an asset, a group of living resources, whose fair value can be measured reliably, shall be carried at a revalued amount, which is its fair value at the date of the revaluation less any accumulated depreciation and accumulated impairment losses. Revaluations shall be made with sufficient regularity to ensure that the carrying amount does not differ materially from that which would be determined using fair value at the reporting date. [GRAP 110.49 and .59 to.73]

Further to the above classification distinction is made between mature and immature resources ”

Definition:

Within the group of living resources, an entity can distinguish between mature and immature living resources, if appropriate depending on the resource’s function in an entity’s operations.

Provided for in the *mSCOA* are the following categories for Living resources at a non-posting level:

- Policing and Protection Animals

- Zoological plants and animals.

Within the above categories posting-level accounts are provided to classify the movement taking place within these categories in specific accounts. The following detail accounts are provided for in *mSCOA*:

Cost

- Opening Balance (non-posting level)
- Acquisitions
- Transfers In/Out
- Disposals
- Gains/Losses on Disposal
- Changes not specifically listed
- Accumulated Depreciation*
 - Opening Balance (non-posting level)
- Depreciation
- Disposals/Transfers Out
- Changes not Specifically Listed
- Accumulated Impairment*
 - Opening Balance (non-posting level)
- Impairment Adjustment/Reversal

Revaluation

- Opening Balance (non-posting level)
- Acquisitions
- Transfers In/Out
- Sales/Biological Assets Classified as held for Sale
- Decrease due to Harvest
- Gains/Losses on Fair Value Adjustments
- Changes not Specifically Listed
- Accumulated Impairment*
 - Opening Balance (non-posting level)
- Impairment Adjustment/Reversal

Liabilities

Definition:

The present obligation of the municipality arising from past events, the settlement of which is expected to result in an outflow from the municipality of resources embodying economic benefits or service potential.

At the highest level the *mSCOA* classification structure distinguish between current and non-current liabilities.

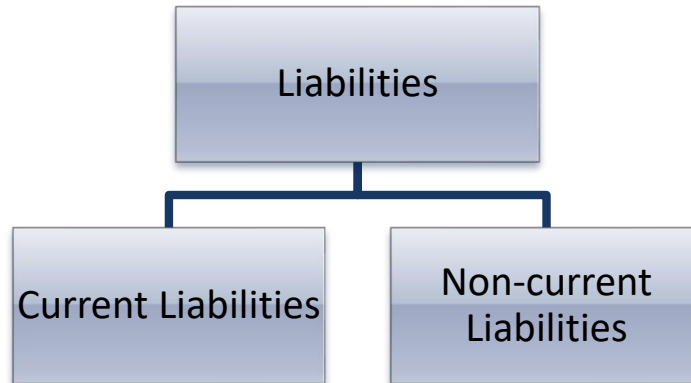

Current Liabilities

Definition:

A liability shall be classified as current when it satisfies any of the following criteria:

- it is expected to be settled in the municipality's normal operating cycle;
- it is held primarily for the purpose of being traded;
- it is due to be settled within twelve months after the reporting date; or
- it does not have an unconditional right to defer settlement of the liability for at least twelve months after the reporting date.

Terms of a liability that could, at the option of the counterparty, result in its settlement by the issue of equity instruments do not affect its classification. All other liabilities shall be classified as non-current.



Illustrations from the Standards of GRAP 1 Presentation of Financial Statements to assist in understanding the classification for current liabilities.

Example 11

	<ul style="list-style-type: none">➤ Some current liabilities, such as government transfers payable and accruals for employee and other operating costs, are part of the working capital used in the normal operating cycle of the entity. Such operating items are classified as current liabilities even if they are due to be settled more than twelve months after the reporting date. The same normal operating cycle applies to the classification of an entity's assets and liabilities. When the entity's normal operating cycle is not clearly identifiable, its duration is assumed to be twelve months.➤ Other current liabilities are not settled as part of the normal operating cycle, but are due for settlement within twelve months after the reporting date or held primarily for the purpose of being traded. Examples are some financial liabilities classified as held for trading (the Standard of GRAP on <i>Financial Instruments</i> provides guidance on the classification of financial liabilities), bank overdrafts, and the current portion of non-current financial liabilities, dividends or similar distributions payable, income taxes and other non-trade payables. Financial liabilities that provide financing on a long-term basis (for example are not part of the working capital used in the entity's normal operating cycle), and are not due for settlement within twelve months after the reporting date, are non-current liabilities.➤ An entity classifies its financial liabilities as current when they are due to be settled within twelve months after the reporting date, even if the original term was for a period of longer than twelve months; and an agreement to refinance, or to reschedule payments, on a long-term basis is completed after the reporting date and before the financial statements are authorised for issue.
--	---

The illustration below provides the high-level group of accounts included in current liabilities. This group of accounts consists of multiple posting level accounts for classifying transactions. If the municipality is required to add a further breakdown to define the posting level the context within which these accounts need to be added is discussed as well as the naming convention supporting the account description:

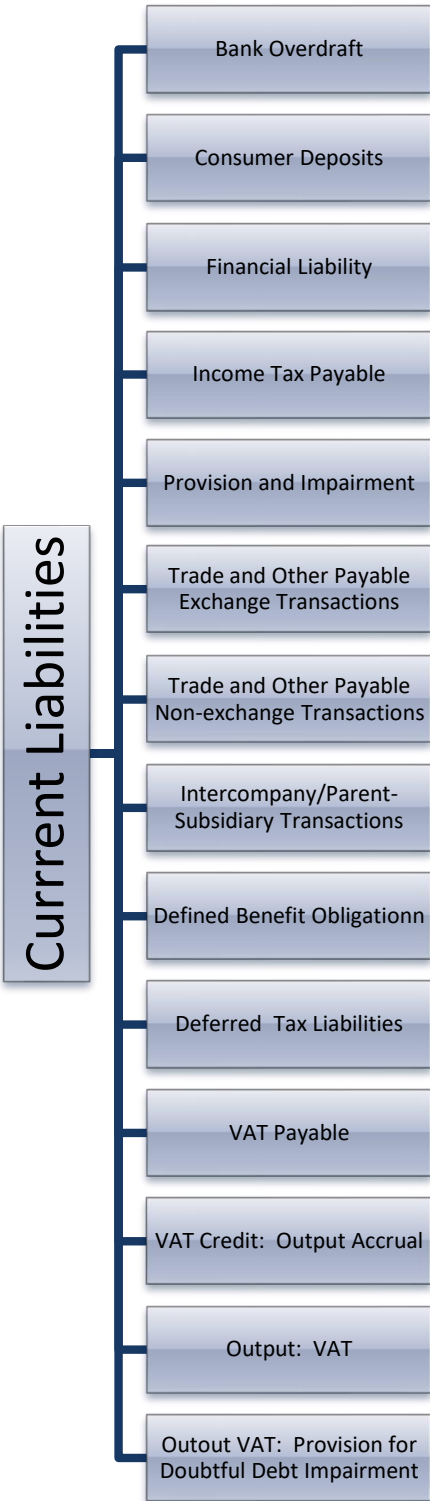

Bank Overdraft

Bank overdraft is discussed as part of the group of accounts dealing with cash and cash equivalents. This account may be dealt with as a bank account if the balance is in debit.

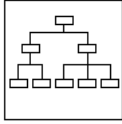

An account description as provided in Version 6.1 being “specify” to be changed by the municipality for the posting level account.

Municipalities need to change the account description labelled as “specify” in Version 6.1 to the financial institution and bank account number of the municipality. This account may be the same as an account used within cash and cash equivalents holding a debit balance.

Consumer Deposits

Deposits paid by consumers for water, electricity, rental deposits and deposits required for other services provided by the municipality. This account should record all amounts deposited with the municipality by customers as security for the payment of bills.

Posting level accounts provided for in *mSCOA* are:

- Electricity
- Street Closure
- Rental Properties
- Water
- Building Plans
- Posters
- Library Books
- Hiring of Decorative Items
- Sewer
- Buying Card
- Valuation Appeal
- Wayleave

- Refuse

Financial Liabilities

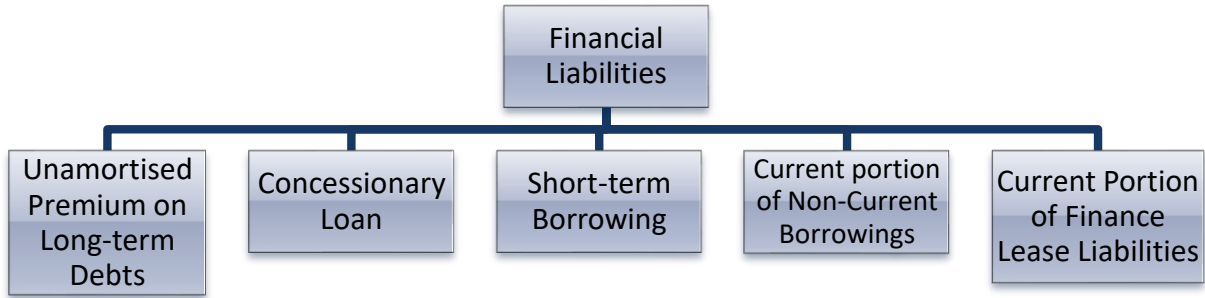

At the highest level, financial liabilities consist of:

Unamortised Premium on Long-term Debts

Definition:

This account should record the excess of the cash value of consideration received over the face value upon the issuance or assumption of long-term debt securities. Amounts recorded in this account should be amortised over the life of each respective issue under a plan which will distribute the amount equitably over the life of the security. The amortization would be on a monthly basis, with the amounts thereof to be credited to account for "interest on long-term debt" or account for "short term interest and other interest expense as appropriate". [NERSA RRM V2: Electricity [225]]

Concessionary Loan

Definition:

A concessionary loan is a loan received by an entity on terms that are not market related. On initial recognition, the entity calculates the part of the concessionary loan that is non-exchange revenue as the difference between the fair value of the loan and the loan proceeds received. The entity accounts for the concessionary loan as a financial liability and non-exchange revenue.

Short-term Borrowing

Definition:

Borrowing is money received with the implied or expressed intention of returning the same or an equivalent to the borrower with same interest.

This group of accounts provide for the portion of non-current liabilities to be redeemed within 12 months from the reporting date.

This account should record in a separate subdivision for each class of liability and series of borrowings the face value of the actually issued and un-matured loans which have not been retired or cancelled; also, the face value of such loans issued by other, the payment of which has been assumed by the municipality, as well as, until maturity, all long-term debt not otherwise provided for.

Separate accounts should be maintained for each class of obligation, and records should be maintained to show for each class all details as to date of obligation, date of maturity, interest dates and rates, security for the obligation, etc.

Definitions:

Annuity and Bullet Loans: This account is for recording annuity loans. An annuity loan is a loan repayable in fixed instalments (annual, monthly or agreed intervals) at a fixed interest rate.

Bankers' Acceptance Certificate: Bankers' acceptance is a promised future payment which is accepted and guaranteed by the bank and drawn on a deposit.

Derivative Financial Liabilities: Derivative Financial Liabilities are financial instruments under contracts that have one or more underlying and, one or more notional amounts. Derivative is a transaction or contract whose value depends on or, as the name implies, derives from the value of underlying assets such as stock, bonds, mortgages, market indices, or foreign currencies. One party with exposure to unwanted risk can pass some or all of the risk to a second party. The first party can

assume a different risk from a second party, pay the second party to assume the risk, or, as is often the case, create a combination. Derivatives are normally used to control exposure or risk.

Government Loans: This account is for recording loans given by national or provincial government.

Local Registered Stock: This account is for recording local registered stock. Local registered stock refers to "stock/ bond" issues made by the municipality through BESA being part of the JSE.

Marketable Bonds: These are for bonds which could be exchanged in an open market prior to maturity.

Non-marketable Bonds: Non-marketable securities are shares held in privately held companies for which there is no ready market. The municipality has to find its own buyer and negotiate its own price if it wish to sell its shares, for example shares in a family owned business.

PPP Liabilities: Recognition of a liability for an asset created by a Public Private Partnership if the asset qualifies for recognition in terms of *GRAP 17 Property, Plant and Equipment*. Where the control approach criteria have been met, the asset would be recognised and accordingly the liability.

Securities: Securities are debt securities (banknotes, bonds and debentures), equity securities (shares and stock) and derivative contracts (forward, futures, options and swaps).

Current portion of Non-Current Borrowings

Posting Level Detail required to be added by the municipality for current and non-current borrowing

Municipalities need to add posting level accounts and the description to include the name of the institution and reference/account number. The same principle applies for current and non-current borrowings.

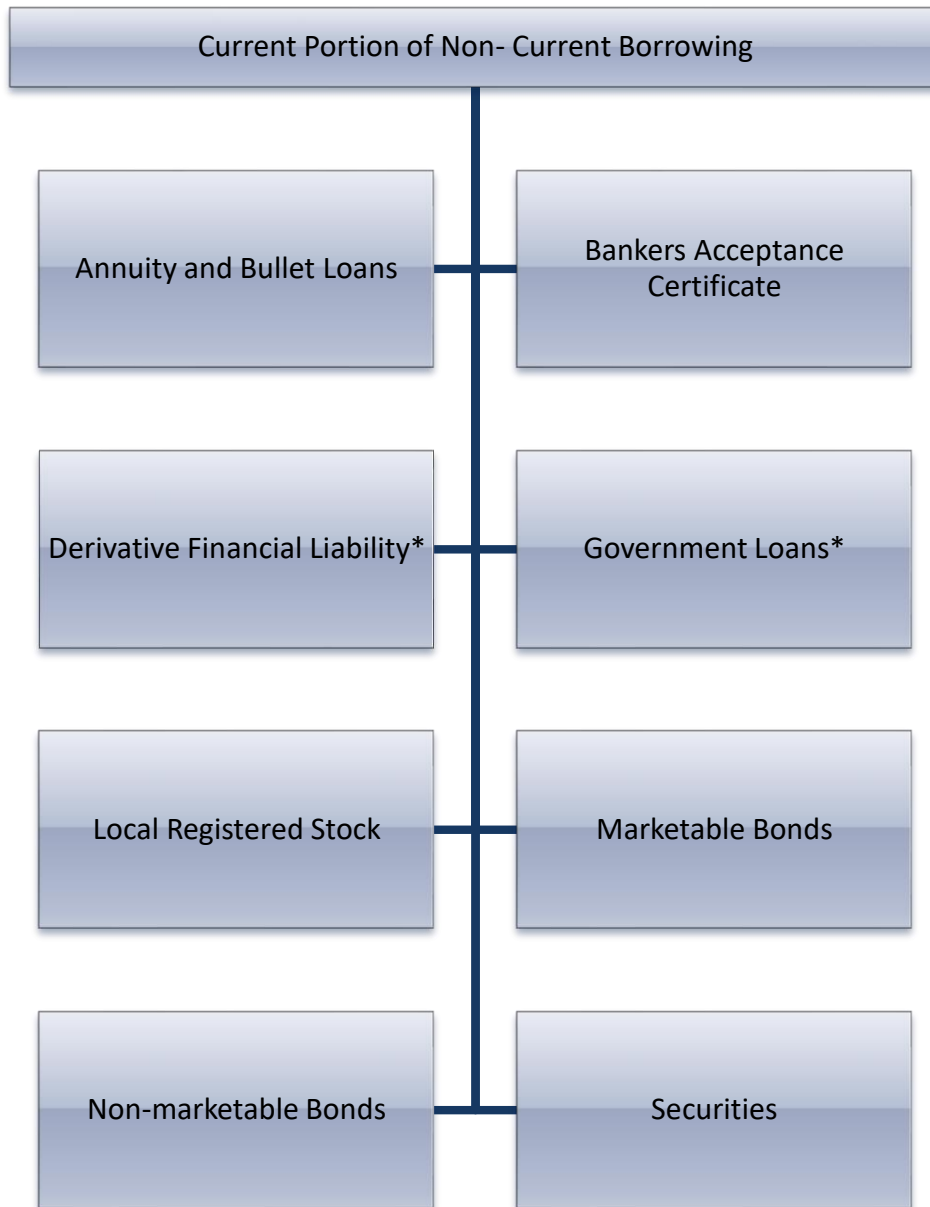

The next level which is a non-posting level the following classification is provided for (except for the financial instruments listed above marked with “*”):

- General Public
- Banks: ABSA/ FNB/ Nedbank/ RMB/ Standard Bank/ Unspecified
- Development Bank of South Africa
- Infrastructure Finance Corporation
- Public Investment Commissioners
- Municipal Pension Funds
- Other Public Pension Funds

- Public Corporation
- Private Enterprises
- Foreign Government and International Organisations

The posting level within the above classification is defined by an account with description “specify”. The municipality need to change the account description by including the account number or reference number for a specific instrument. The account set-up should align with the Current Borrowing Section in the Item: Liabilities Segment.

Current/ Non-current portion of Finance Lease Liabilities and Operating Lease liabilities

Definition:

At the commencement of the lease term, lessees shall recognise finance leases as assets and liabilities in their statement of financial position at amounts equal to the fair value of the leased property or, if lower, the present value of the minimum lease payments, each determined at the inception of the lease.

The discount rate to be used in calculating the present value of the minimum lease payment is the interest rate implicit in the lease, if this is the determining practice; if not, the lessee’s incremental borrowing rate shall be used. Any initial direct costs of the lessee are added to the amount recognised as an asset.

If for the presentation of liabilities on the face of the statement of financial position a distinction is made between current and non-current liabilities, the same distinction is made for lease liabilities.

Minimum lease payments shall be apportioned between the finance charge and the reduction of the outstanding liability.

The finance charge shall be allocated to each period during the lease term so as to produce a constant periodic rate of interest on the remaining balance of the liability. Contingent rents shall be charged as expenses in the periods in which they are incurred.

In practice, in allocating the finance charge to periods during the lease term, a lessee may use some form of approximation to simplify the calculation.

In addition, the requirements for disclosure in accordance with the Standards of GRAP on Investment Property, Property, Plant and Equipment, Intangible Assets, Agriculture and Impairment of Assets apply to lessees for assets leased under finance leases.

Although assets leased under operating leases have a different treatment in terms of GRAP 13 the *m*SCOA chart also makes provision for the current and non current portion of operating lease liabilities. Municipalities must ensure that the classification of lease liabilities are captured in terms of the signed lease agreements.

Posting Level Detail required to be added by the municipality for current portion of finance lease liability and non-current finance lease liability

Municipalities need to add posting level accounts and the description to include the name of the institution and reference/account number. The same principle applies for current and non-current finance lease liability.

Income Tax Payable

Income tax payable and receivable is the same account. Please refer to the discussion under current assets on income tax receivable in this regard.

Current and Non-Current Provision and Impairment

Provision

Definition:

Provision is a liability of uncertain timing or amount. “Current” provision would be for the “anticipated” liability to realise within twelve months from the reporting date.

The *Standard of GRAP 19 Provisions, Contingent Liabilities and Contingent Assets*, define provisions, identify the circumstances in which provisions should be recognised, how they should be measured and the disclosures that should be made about them in the financial statements to enable users to understand their nature, timing and amount.

Provisions need to be reviewed at each reporting date and adjusted to reflect the current best estimate. If it is no longer probable that an outflow of resources embodying economic benefits or service potential will be required to settle the obligation, the provision shall be reversed.

Where discounting is used, the carrying amount of a provision increases in each period to reflect the passage of time. This increase is recognised as an interest expense.

The periodic unwinding of the discount shall be recognised in surplus or deficit as a finance cost as it occurs.

A provision shall be used only for expenditures for which the provision was originally recognised.

Only expenditures that relate to the original provision are set against it. Setting expenditures against a provision that was originally recognised for another purpose would conceal the impact of two different events.

A liability shall be classified as current when it satisfies any of the following criteria:

- it is expected to be settled in the municipality's normal operating cycle;
- it is held primarily for the purpose of being traded;
- it is due to be settled within twelve months after the reporting date; or
- the entity does not have an unconditional right to defer settlement of the liability for at least twelve months after the reporting date.

All other liabilities shall be classified as non-current.

Impairment

Reduction in the value of an asset because the asset no longer generates the benefits expected earlier as determined through periodic assessments. This could happen because of changes in market value of the asset, business environment, government regulations, etc.

Cognisance is taken that impairment is not dealt with in the *Standard of GRAP 19 Provisions, Contingent Liabilities and Contingent Assets*³. Impairment have been provided under the Item assets classification to ensure the recording of the impairment are linked to the asset affected.

Provision and Impairment (Current/ Non-current) provides for the following classification at a non-posting level:

³ Standards of GRAP dealing with Impairment: GRAP 21 Impairment of Non-cash generating Assets/ GRAP 26 Impairment of Cash-generating Assets/ GRAP 104 Financial Instruments.

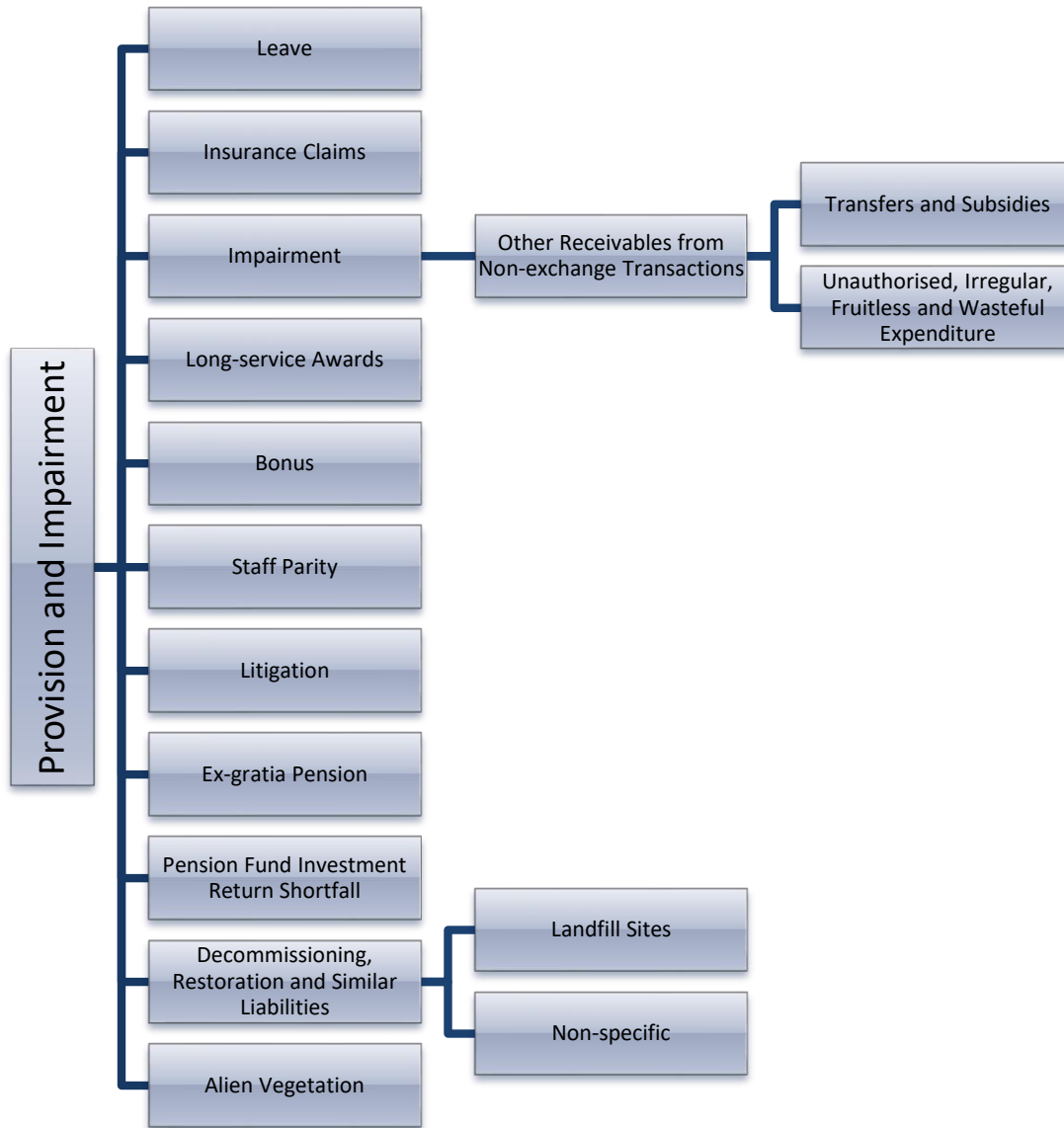

Definitions:

Leave: Vacation or annual leave is a short-term employee benefit. Vacation leave can either be vested or non-vested. "Vested" vacation leave means that the employee is entitled to a cash payment for unused leave, for example after a certain period of time has elapsed or on resignation. "Non-vested" leave means that if employees do not use their leave, it is forfeited. Unless a municipality has an enforceable right to defer the encashment or utilisation of leave, the liability is treated as a current liability, for example a municipality does not have an unconditional right to defer settlement if employees can utilise their leave due at any time or demand that their unused leave be paid.

Insurance Claims: This account is for recording provisions made for insurance excess payment or if the municipality is self-insured, to provide for claims from third parties for which either the amount or time of payment is uncertain.

Landfill Sites: The initial estimates of the cost of rehabilitation of landfill sites are included in the cost of the asset. The contra entry is recorded in this account. The obligation to incur such costs arises either when the entity acquires the asset, or as a result of using the asset over a certain period, except when the asset is used to produce inventory during the period. This account would also provide for the discounting interest on the present obligation recognised in the surplus or deficit for the period.

Long-service Awards: This account is for recording the provision made for long-service awards paid to municipal staff in terms of a policy.

Bonus: This account is for recording the provision made for performance bonuses payable to municipal staff in terms of a policy.

Staff Parity: This account is for making provision to give equal benefits to all staff based on specific criteria.

Litigation: This account is for recording of the provisions made for legal claims against the municipality.

Ex-gratia Pension: Ex-gratia pensions payable to former employees who did not belong to a pension fund due to exceeding the age limits at the time of appointment. In terms of GRAP 25 provision should be made for the future payments of the pensions to the former employees. The short-term portion is the amount to be paid in the next financial year. It is being calculated by way of Actuarial Valuations. Ex-gratia pension payments to former employees who did not belong to a pension fund in terms of the former Municipal Ordinance No 20 of 1974.

Pension Fund Investment Return Shortfall: The shortfall is an Employee Benefit which emanated from a shortfall in the investment returns from the pension fund. The rules of the fund states that each municipality must contribute (make good) an amount if the pension fund returns are less than 5 per cent for that year; if this did not happen in 1 year and the amount had to be provided in terms of GRAP 25.

Decommissioning, Restoration and Similar Liabilities: Municipalities may have obligations to dismantle, remove and restore items of property, plant and equipment. Under the Standard of GRAP on Property, Plant and Equipment the cost of an item of property, plant and equipment includes the initial estimate of the costs of dismantling and removing the item and restoring the site on which it is located, the obligation for which the municipality incurs either when the item is acquired or as a consequence of having used the item during a particular period for purposes other than to produce inventories during the period. Provision for clearing alien vegetation.

The posting levels are set within the above structure providing for accounts giving a reconciliation from “opening to closing balance”. Opening balance is not a posting level account but an “automated account” rolling the closing balance at year-end closure forward to the new financial year. The closing balance account provides for the “movement accounts” including opening balance to automatically close to this account at year end closure. The closing balance to be rolled forward to the new financial year. The movement accounts (excluding opening and closing balance accounts) provides for:

- Increases
- Reductions (Outflow of Economic Benefits)
- Reductions (without Outflow of Economic Benefits)
- Reversals
- Increases (Passage of Time/Discounted Rate)

Decommissioning Restoration and Similar Liabilities

Municipalities may have obligations to dismantle, remove and restore items of property, plant and equipment. Under the *Standard of GRAP 17 on Property, Plant and Equipment*, the cost of an item of property, plant and equipment includes the initial estimate of the costs of dismantling and removing the item and restoring the site on which it is located, the obligation for which the municipality incurs either when the item is acquired or as a consequence of having used the item during a particular period for purposes other than to produce inventories during that period.

Events that may change the measurement of an existing decommissioning, restoration or similar liability should be accounted for:

- A change in the estimated outflow of resources embodying economic benefits (for example cash flows) or service potential required to settle the obligation.
- A change in the current market-based discount rate (this includes changes in the time value of money and the risks specific to the liability).
- An increase that reflects the passage of time (also referred to as the unwinding of the discount).

Changes in the measurement of an existing decommissioning, restoration and similar liability that result from changes in the estimated timing or amount of the outflow of resources embodying economic benefits or service potential required to settle the obligation, or a change in the discount rate, shall be accounted for as indicated below.

If the related asset is measured using the cost model:

- subject to changes in the liability there shall be additions to, or deductions from, the cost of the related asset in the current period.
- the amount deducted from the cost of the asset shall not exceed its carrying amount. If a decrease in the liability exceeds the carrying amount of the asset, the excess shall be recognised immediately in surplus or deficit.

- if the adjustment results in an addition to the cost of an asset, the entity shall consider whether this is an indication that the new carrying amount of the asset may not be fully recoverable. If there is such an indication, the entity shall test the asset for impairment by estimating its recoverable amount, and shall account for any impairment loss, in accordance with the Standards of GRAP on impairment of assets.

If the related asset is measured using the revaluation model:

- changes in the liability alter the revaluation surplus or deficit previously recognised on that asset, so that: (i) a decrease in the liability shall be credited directly to revaluation surplus in net assets, except that it shall be recognised in surplus or deficit to the extent that it reverses a revaluation deficit on the asset that was previously recognised in surplus or deficit; and (ii) an increase in the liability shall be recognised in surplus or deficit, except that it shall be debited directly to revaluation surplus in net assets to the extent of any credit balance existing in the revaluation surplus in respect of that asset;
- that would have been recognised had the asset been carried under the cost model, the excess shall be recognised immediately in surplus or in the event that a decrease in the liability exceeds the carrying amount deficit;
- a change in the liability is an indication that the asset may have to be revalued in order to ensure that the carrying amount does not differ materially from that which would be determined using fair value at the reporting date. Any such revaluation shall be taken into account in determining the amounts to be taken to surplus or deficit and net assets under.

If a revaluation is necessary, all assets of that class shall be revalued; and the Standard of GRAP 1 on Presentation of Financial Statements requires disclosure on the face of the statement of changes in net assets of each item of revenue or expense that is recognised directly in net assets. In complying with this requirement, the change in the revaluation surplus arising from a change in the liability shall be separately identified and disclosed as such.

The adjusted depreciable amount of the asset is depreciated over its useful life. Therefore, once the related asset has reached the end of its useful life, all subsequent changes in the liability shall be recognised in surplus or deficit as they occur. This applies under both the cost model and the revaluation model.

The periodic unwinding of the discount shall be recognised in surplus or deficit as a finance cost as it occurs. Capitalisation under the *Standard of GRAP 5 on Borrowing Costs* is not permitted.

Onerous Contracts

If the municipality has a contract that is onerous, the present obligation (net of recoveries) under the contract shall be recognised and measured as a provision.

Trade and Other Payable Exchange Transactions

Definition:

Accounts that are owed to suppliers (trade creditors) as distinguished from accrued interest, rent, salaries, taxes, and other such accounts. In exchange transactions, the municipality receives equal value for the payment made to the creditor.

The table below provides the posting level accounts (unless otherwise indicated) set-up in *mSCOA* for the group of accounts:

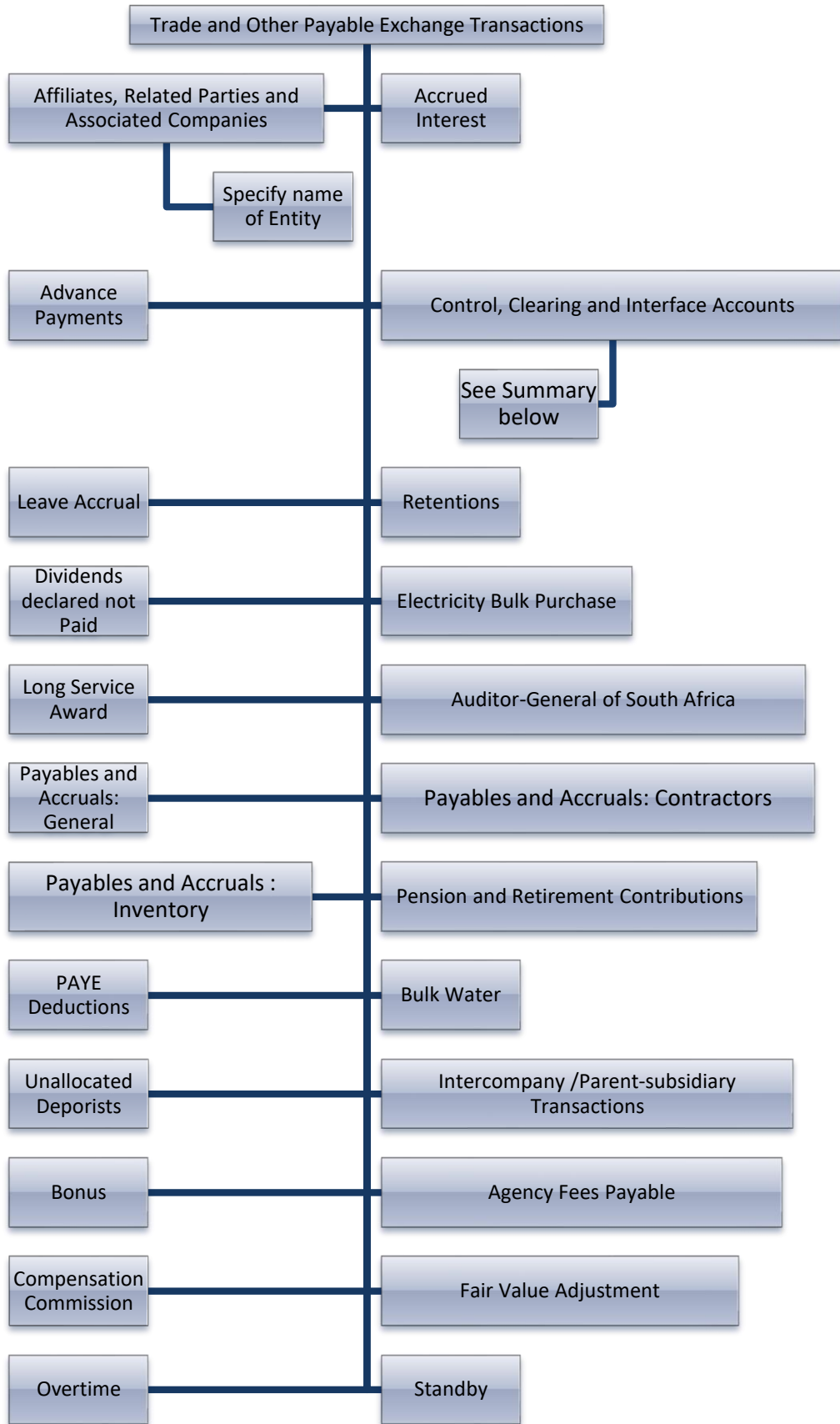

Definitions:

Affiliates, Related Parties and Associated Companies: These accounts should record amounts owing to associated companies on notes, drafts, acceptance, or other similar evidences of indebtedness, and, open accounts payable on demand, of not more than one year from date of issue or creation.

Accrued Interest: Accrued interest is the amount of loan interest that has already occurred, but has not yet been paid to the lender by the borrower. The accrued interest will be reported by the borrower as both an expense on its statement of financial performance, and a current liability on its statement of financial position.

Advance Payments: A liability account used to record an amount received from a customer before a service has been provided or before goods have been shipped. This account is referred to as a deferred revenue account and could be “entitled customer deposits” or “unearned revenues”. This account would include debtor’s accounts with credit balances.

Control, Clearing and Interface Accounts (non-posting level): This group of accounts are used for the recording of un-cleared credit amounts resulting from control, interface and clearing accounts required by the general ledger system to import transactions/ balances from sub ledger or other systems such as billing, procurement, asset modules, payroll, electronic funds transfer (EFT) processes, etc. This account need to clear automatically, without manual interference resulting from timing differences.

Leave Accrual: A statement of financial position liability account which reports the total amount owed to employees at the reporting date for future vacation days as a result of the employees' past work. The leave liability will be treated as an accrual or a provision depending on the level of uncertainty attached to either the timing or amount; the less uncertainty, the more likely that the liability will be an accrual. Vacation or annual leave is a short-term employee benefit. Vacation leave can either be vested or non-vested. "Vested" vacation leave means that the employee is entitled to a cash payment for unused leave, for example after a certain period of time has elapsed or on resignation. "Non-vested" leave means that if employees do not use their leave, it is forfeited. Unless a municipality has an enforceable right to defer the encashment or utilisation of leave, the liability is treated as a current liability, for example a municipality does not have an unconditional right to defer settlement if employees can utilise their leave due at any time or demand that their unused leave be paid.

Retentions: Usually an amount of money held back by the municipality to ensure that the contractor works properly. This retention money is due to the contractor as the work is completed, but will not be paid out. This is to ensure that contractors correct any defective work. Normally half of the retention money is paid to the contractor when the project is delivered (or the engineer issues the Certificate of Completion) and the other half is paid within 14 days after the end of the defects liability period.

Dividends Declared not Paid: Dividends declared by the company but not yet paid to the shareholders

Electricity Bulk Purchase: This account should record all payments and accruals due to service providers resulting from the purchase of electricity.

Long Service Award: Long service awards payable to employees in terms of a "long service award" policy.

Auditor-General of South Africa: Unpaid amounts due to the Auditor-General of South Africa.

Payables and Accruals: General: Any other payables and accruals not separately provided for in the detail accounts for trade creditors to be included here.

Payables and Accruals: Contractors: All payables and accruals directly attributable to the payment due to contractors for services delivered as trade creditors to be included here.

Payables and Accruals: Inventory: All payables and accruals directly attributable to the purchasing of inventory for trade creditors to be included here.

Pension and Retirement: Accrual provided for pension and retirement contributions deducted from employees' salaries but not yet paid to the respective institutions.

PAYE Deductions: UIF, SDL, PAYE, Workmen's Compensation deducted but not yet paid to SARS or other authorities.

Water Bulk: This account should record all payments and accruals due to service providers resulting from the purchase of water.

Unallocated Deposits: Direct deposits not sufficiently referenced to allocated payments to customer accounts.

Intercompany/ Parent Subsidiary Transactions: This account should record all current portions of intercompany loans payable between parent municipalities and their subsidiary municipal entities.

Bonus: Account to be used for bonuses not paid at the reporting date.

Agency Fees Payable: Amounts due by the municipality resulting from agency services provided on behalf of national/ provincial departments and district municipalities for example collection of traffic fines for the provincial department of transport.

Compensation Commission (COID): This account should be used for recording accruals due to COID. The Compensation for Occupational Injuries and Diseases Act, 1993 was formerly known as the Workmen's Compensation Act, which was implemented purely to protect an employee injured or killed in the line of duty. It is, in effect an 'umbrella' insurance for South Africa's workers. In a nutshell, in terms of this legislation employees are precluded from suing their employers (subject to a few exceptions) and all employers are compelled to register and to pay contributions to the fund (subject to a few exceptions). Although the owner of every business in South Africa is obligated by law to pay regular amounts to the Commissioner, municipalities may apply for exemption on condition to self-insure the underlying risk.

The following posting levels accounts were added to "Control, Clearing and Interface" accounts at the request of specific system vendors:

- Salary Clearing and Control

- Salary Control
- Travel Control
- Leave Control
- Tax Control
- UIF Control
- Skills Control
- Pension Control
- Medical Aid Control
- Group Life Control
- Unions Control
- Employee Deductions FICS
- Employee Net Pay and Bond Payment
- Garnishee Payments
- Disposal Clearing
- Goods Received/ Invoice Received
- Prepaid Electricity
- Cash and Bank
- Licensing and Registration
- Inventory Stores

Trade and Other Payable Non-Exchange Transactions

Definition:

Accounts owed to suppliers resulting from non-exchange transactions

At the highest level this classification consists of two groups of accounts, being transfers and subsidies payable and unspent.

Definition:

Transfers and Subsidies Payable: Transfers and subsidies not made during the year payable to other entities by the municipality. This account excludes the unspent portion of transfers and subsidies received by municipalities.

Transfer and Subsidies Unspent: Transfers and subsidies received by the municipality but not used potentially refundable to the grantee.

The structure makes distinction between capital and operational transfers and subsidies with a further distinction based on whether the allocation is received “in-kind” or in “monetary value”.

Posting level accounts are defined within the structure illustrated below. If posting level accounts need to be set-up the requirement therefore is further discussed in the table at the end of the discussion on “trade and other payable non-exchange transactions”.

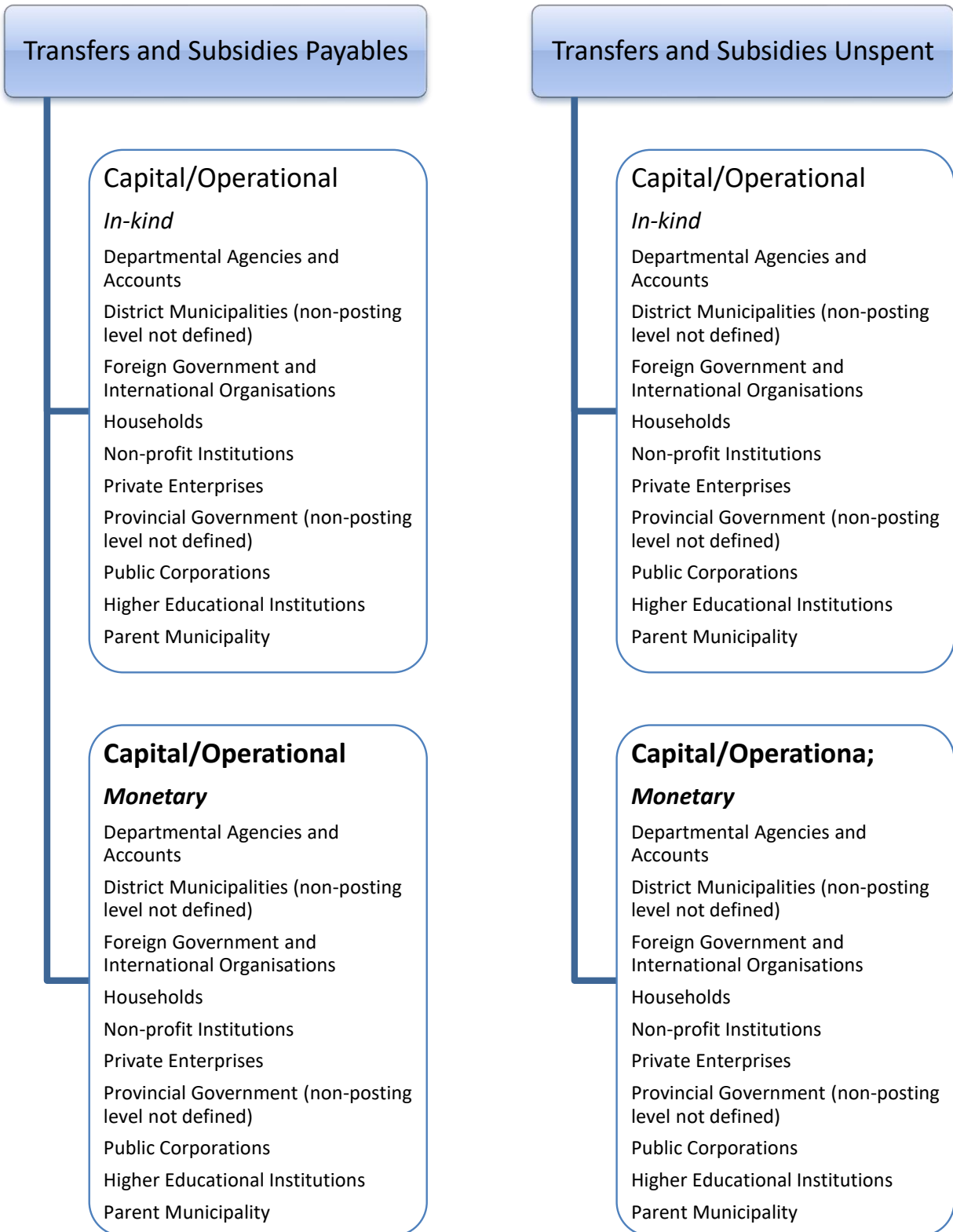

Posting Level Detail required to be provided by the municipality to National Treasury for setting up posting level accounts

Provincial Government

The provincial treasuries in consultation with the departments within the province need to provide guidance to the Municipalities and standardise the use of the posting levels of which the main classifications were provided in the *mSCOA* version 6.3 as Infrastructure and Capacity building.

The original classification was retired and replaced with two main headings: Infrastructure and Capacity building with posting levels that is named “specify”. Each Provincial Government will have to provide guidance to the Municipalities on how the reporting must be structured on the grants allocated annually. The layout of the grant reporting must correspond between the Item Liabilities Unspent grants, the Item Revenue Transfers and Subsidies and the Fund segment. This will allow for alignment of reporting in terms of GRAP 23 and data string credibility. The posting levels is not prescribed by National Treasury

District Municipalities

The provincial treasuries in consultation with the district municipalities within the province had to provide to the National Treasury the detail of transfers and subsidies made to municipalities, for inclusion already in *mSCOA* Version 5.5 to define posting level accounts. This would-be part of the annual reviews of the *mSCOA* following implementation.

VAT Payable (Control)

This is a posting level account added specifically for extracting information for the VAT 201 return.

Definition:

This account should record input and output tax transactions during the accounting period, corresponding with the debits credits being made to the appropriate accounts for input, output VAT and VAT refunds/offsets.

VAT Credit: Output tax Accrual

This is a posting level account added for extracting information for the VAT 201 return.

Definition:

Accrual of Output Tax on Receivables.

Output tax

This is a posting level account added for extracting information for the VAT 201 return.

Definition:

VAT 201 - VAT on Payments received from Debtors.

Output tax: Provision for Doubtful Debt Impairment

This is a posting level account does not impact on the information provided in the VAT 201 return.

Definition:

Output tax on the Provision for Doubtful Debt.

Intercompany/ Parent Subsidiary Transactions

This is a posting level account specifically for transactions between the municipality and entities.

Definition:

This account should record all current portions of Intercompany Loans payable between parent municipalities and their subsidiary municipal entities.

Defined Benefit Obligations

Distinction is made at posting level for medical and pension within the defined benefit obligations.

Definition:

This account should record the unamortised portion of past service costs related to future benefits and pensions which will be expensed in future periods. Defined benefit plan obligations for medical and pension benefits.

Deferred Tax Liabilities

This is a posting level account to be used by taxpaying entities.

Definition:

A liability recorded on the statement of financial position that may be used to reduce the subsequent period's income tax expense.

Non-current Liabilities

The diagram below provides the high-level group of accounts included in non-current liabilities. This group of accounts consists of multiple posting level accounts for classifying transactions. If the municipality is required to add a further breakdown to define the posting level the context within which these accounts need to be added is discussed as well as the naming convention supporting the account description:

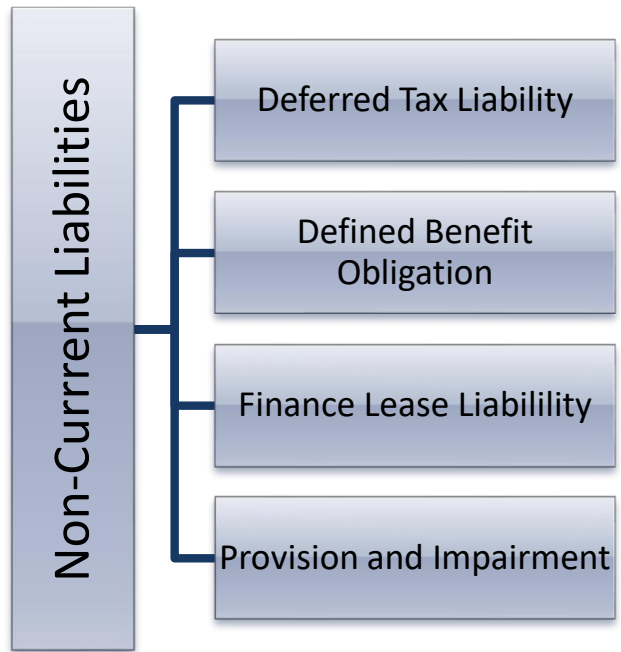

Deferred Tax Liabilities

Refer to the discussion of deferred tax liabilities included in current assets in this regard.

Definition:

A liability recorded on the statement of financial position that may be used to reduce a subsequent period's income tax expense.

Defined Benefit Obligations

Refer to the discussion of deferred tax liabilities included in current assets in this regard.

This account should record the unamortised portion of past service costs related to future benefits and pensions which will be expensed in future periods.

Financial Liabilities

Definition:

This account is to be used for recording any other "financial liability" not separately recorded somewhere else. Long-term debt with an original maturity of more than one year, other than Mortgage and Debenture Bonds and Advances from Associated Companies.

Borrowings

Refer to the discussion of deferred tax liabilities included in current assets in this regard.

Definition:

This account is for recording non-current borrowing. Borrowing is money received with the implied or expressed intention of returning the same or an equivalent to the borrower with same interest. This account should record in a separate subdivision for each class and series of borrowings the face value of the actually issued and un-matured loans which have not been retired or cancelled; also, the face value of such loans issued by other the payment of which has been assumed by the municipality, as well as, until maturity, all long-term debt not otherwise provided for. Separate accounts should be maintained for each class of obligation, and records should be maintained to show for each class all details as to date of obligation, date of maturity, interest dates and rates, security for the obligation, etc. [NERSA RRM V2: Electricity [221]]

Finance Lease Liability

Refer to the discussion of deferred tax liabilities included in current assets in this regard.

Definition:

A non-current finance lease liability.

Operating Lease Liability

Refer to the discussion of deferred tax liabilities included in current assets in this regard.

Definition:

Unamortised balance for straight lining of operational lease payments.

Provision and Impairment

Refer to the discussion of deferred tax liabilities included in current assets in this regard.

Definition:

Provision is a liability of uncertain timing or amount. Impairment - Reduction in the value of an asset because the asset no longer generates the benefits expected earlier as determined through periodic assessments. This could happen because of changes in market value of the asset, business environment, government regulations, etc.

Net Assets

Reserves and Funds “Net assets” is the term used in the *Standards of GRAP 1 on the Preparation of Financial Statements* to refer to the residual measure in the statement of financial position (assets less liabilities). Net assets may be positive or negative.

Definition:

The residual interest in the assets of the entity after deducting all its liabilities.

Although net assets are defined as a residual, it may be sub classified in the statement of financial position. Such classifications can be relevant to the decision-making needs of the users of financial statements when they indicate legal- or other restrictions on the ability of the entity to distribute or otherwise apply its net assets.

The classifications provided for in the *mSCOA* in this regard are:

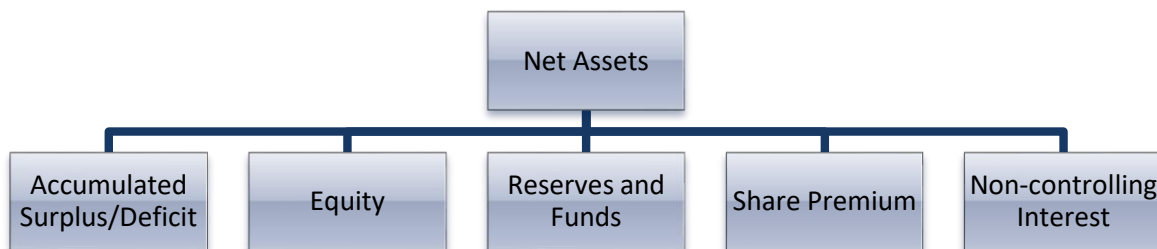

Accumulated Surplus/(Deficit)

Definition:

Retained earnings or accumulated deficit being the cumulative effect of differences between revenue and expenditure as per statement of financial performance.

This group of accounts provides for the following posting level accounts (unless indicated otherwise) with no further breakdown required:

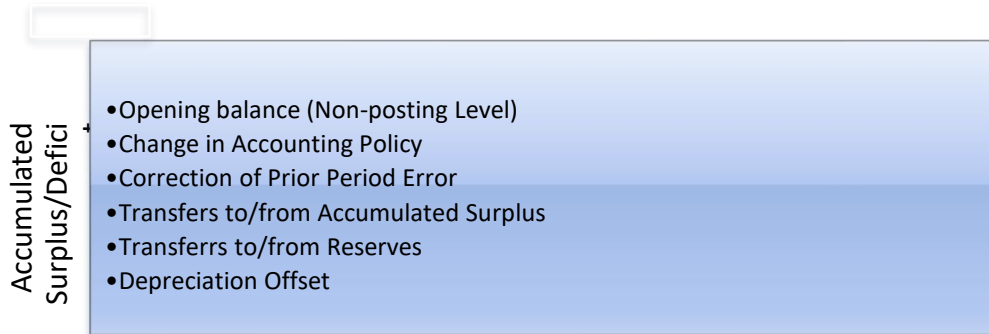

Equity

Defined under “Equity” in the *mSCOA* are the following posting level accounts:

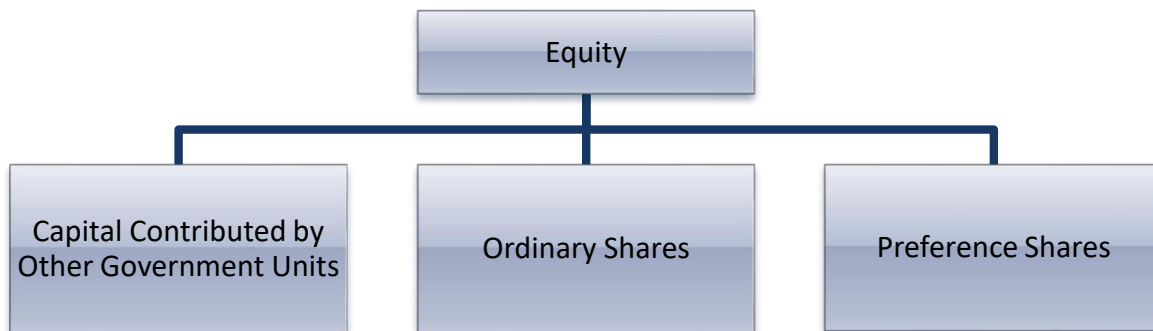

Definitions:

Capital Contributed by Other Government Units: This account provides for capital contributions made to the entity by other government units. “Contributions from owners” means future economic benefits or service potential that have been contributed to the entity by parties external to the entity, other than those that result in liabilities of the entity, and those that establish a financial interest in the net assets of the entity, which conveys entitlement both to distributions of future economic benefits or service potential by the entity during its life, such distributions being at the discretion of the owners or their representatives, and to distributions of any excess of assets over liabilities in the event of the entity being wound up; and/ or can be sold, exchanged, transferred or redeemed.”

Ordinary Shares: An ordinary share represents equity ownership in a company and entitles the owner to a vote in matters put before the shareholders in proportion to their percentage ownership in the company. Any shares that are not preferred shares and do not have any predetermined dividend amounts.

Preference Shares: Preference shares are shares with fixed dividend yields payable at defined intervals.

Non-controlling Interest

The interest in the net assets in a controlled entity not attributable, directly or indirectly, to a controlling entity. The accounts are set-up to provide a movement from the opening to the closing balance:

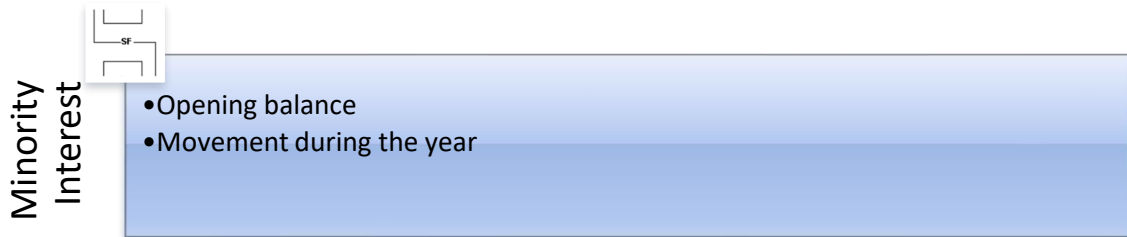

Reserves and Funds

The creation of reserves is sometimes required by statute or other law in order to give the municipality and its creditors an added measure of protection from the effects of future losses. The existence and size of these legal, statutory and tax reserves is for information to be relevant to the decision-making needs of users.

Transfers to such reserves are deemed to be appropriations of retained earnings, and not expenses. Any such transfers are disclosed in the statement of changes in net assets.

The classifications provided for in the *mSCOA* in this regard are:

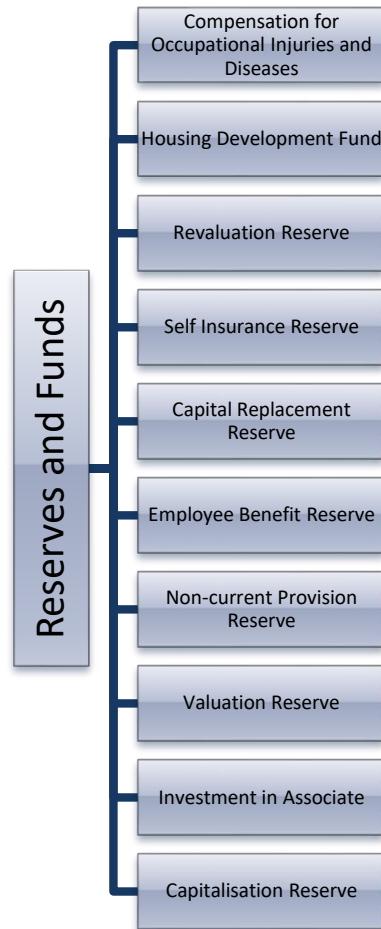

Definitions:

COID Reserve: This reserve is created to make provision for claims that have been submitted to the Commission for Occupational Injuries and Diseases. This is a self-insurance reserve.

Housing Development Fund: The Housing Development Fund was established in terms of the Housing Act, 1997 (Act No 107 of 1997). Loans from national and provincial government used to finance housing selling schemes undertaken by the Municipality were extinguished on 1 April 1998 and transferred to a Housing Development Fund. Housing selling schemes both complete and in progress as at 1 April 1998, were also transferred to the Housing Development Fund. In terms of the Housing Act, 1997 all proceeds from housing developments which include rental income and sale of houses must be paid into the Housing Development Fund. Monies standing to credit of the Housing Development Fund can be used only to finance housing developments within the municipal areas subject to the approval of the Provincial MEC responsible for housing. Since the Housing Development Fund was established in terms of legislation it may be reported separately in the Statement of Financial Position and the Statement of Changes in Net Assets.

Revaluation Reserve: A Revaluation Reserve is established upon revaluation of a class of property, plant and equipment (PPE). GRAP 17 does not require entities to revalue items of property, plant and equipment. It does however; permit entities to revalue assets if they wish to do so. In other words,

voluntary revaluation of land and building, and other assets for which there is an active market, is permitted. When land and buildings are revalued, a Non-Distributable Reserve (Revaluation NDR) is created. A transfer must be made from the NDR to the accumulated surplus account via the Statement of Changes in Net Assets to offset the additional depreciation charged as a result of the revaluation.

Self-Insurance Reserve: The self-insurance reserve is issued where the municipality/ entity opted to be "self-insurer".

Capital Replacement Reserve: This reserve is to be used for future capital expenditure from own funds only and may not be used for maintenance or other operating expenditure. The capital replacement reserve must be cash-backed. The annual contribution to be based on a funding and reserve policy.

Employee Benefit Reserve: The aim to the reserve is to ensure sufficient cash resources are available for the future payment of employee benefits. The contributions to the reserve must be made in accordance with the directives set in a funding and reserve policy.

Non-current Provision Reserve: The aim to the reserve is to ensure sufficient cash resources are available for the future payment of non-current provisions. The contributions to the reserve must be made in accordance with the directives set in a funding and reserve policy.

Valuation Reserve: The aim to the reserve is to ensure sufficient cash resources are available to undertake a general valuation as required in terms of the Municipal Property Rates Act, 2004 (Act No. 6 of 2004) as amended. The contributions to the reserve must be made in accordance with the directives set in a funding and reserve policy.

Investment in Associate: Ring-fencing of Reserves and Funds relating to Investment in associate,

Capitalisation Reserve: This reserve represents amount previously accumulated that were recovered from consumers through rates and tariffs and that have been used to acquire items of Property, Plant and Equipment. These amounts are therefore not available for any other purpose. This reserve should be depleted over time as no replenishment take place. This fund had been created from the consolidation of various statutory funds resulting from ordinances at the time of adopting the Standards of GRAP.

Distinction is made within the Housing Development Fund for the "Operating Fund" and the "Loan Extinguished". The definition of the accounts is as indicated, on a non-posting level.

- Housing Development Fund: Operating Fund - Section 15(5) and 16 of the Housing Act, 1997 (Act No. 107 of 1997), which came into operation on 1 April 1998, requires that the municipality ensures that a separate housing operating account (known as the Housing Development Fund) is maintained by the municipality as required by sections 15(5) and 16 of the Housing Act No 107 of 1997. The net proceeds of any letting, sale of property or alienation, financed previously from government housing funds, are paid into a separate

operating account and is utilised by the municipality for housing development in accordance with the National Housing Policy.

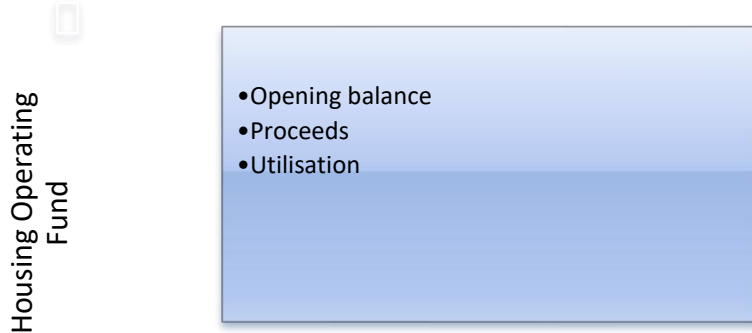

- Housing Development Fund: Loans Extinguished - Loans extinguished by government on 1 April 1998. This account would present the difference between provincial and national government loans extinguished and used to finance housing selling schemes undertaken by municipalities with a transfer of the related assets (complete and in progress) to the fund. Monies standing to the credit of the Housing Development Fund could only be used to finance housing developments within the municipal areas subject to the approval of the Provincial MEC responsible for Housing.

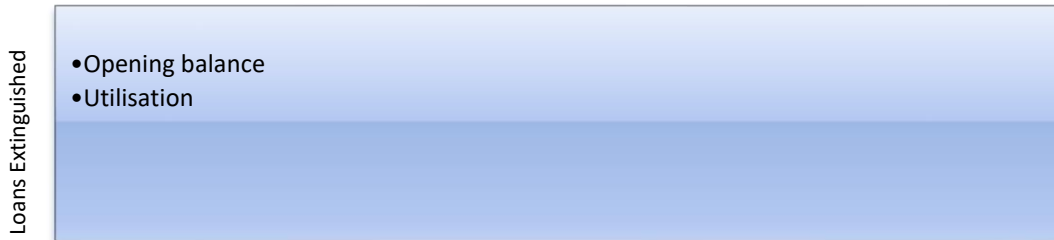

The posting level accounts available at a posting level, unless otherwise indicated excluding the Housing Development Fund are:

Reserves and Funds

- Opening balance
- Current Period Revaluation Increase/Decrease (only applicable to the Revaluation Reserve)
- Transfers to/from Accumulated Surplus
- Disposal of Assets

Share Premium account at a posting level provide for the excess amount received over the par value of issued shares, only applicable to municipalities and municipal entities.

mSCOA Implementation

Municipalities by now, have progressively implemented the *mSCOA*.

The system developers responsible for applications commonly used by the municipalities are responsible for enhancing their software to be operated by business processes and are subject to customisation based on the unique requirements of client municipalities, with one of the primary objectives to assist municipalities in achieving compliance with the *mSCOA* classification framework.

National Treasury have provided comprehensive guidance in *mSCOA* Circular no.7 to 14 as implementation challenges have been identified.

Annual Maintenance and Matters Pending

Annual Maintenance

There were several changes made to the item segment assets, liabilities and net assets on the version 6.7 of the chart and the detailed changes is available on the National Treasury website at www.treasury.gov.za.

Matters Pending

There were no 'matters pending' identified for the Item Assets, Liabilities and Net Assets Segment at the time of finalising the Project Summary Document (PSD) for Version 6.7.